



# MK4000 MicroKiosk for CE .NET 5.0

## Product Reference Guide





***MK4000 MicroKiosk for CE .NET 5.0  
Product Reference Guide***

*72E-121864-02*

*Revision A*

*May 2010*

© 2010 by Motorola, Inc. All rights reserved.

No part of this publication may be reproduced or used in any form, or by any electrical or mechanical means, without permission in writing from Motorola. This includes electronic or mechanical means, such as photocopying, recording, or information storage and retrieval systems. The material in this manual is subject to change without notice.

The software is provided strictly on an “as is” basis. All software, including firmware, furnished to the user is on a licensed basis. Motorola grants to the user a non-transferable and non-exclusive license to use each software or firmware program delivered hereunder (licensed program). Except as noted below, such license may not be assigned, sublicensed, or otherwise transferred by the user without prior written consent of Motorola. No right to copy a licensed program in whole or in part is granted, except as permitted under copyright law. The user shall not modify, merge, or incorporate any form or portion of a licensed program with other program material, create a derivative work from a licensed program, or use a licensed program in a network without written permission from Motorola. The user agrees to maintain Motorola’s copyright notice on the licensed programs delivered hereunder, and to include the same on any authorized copies it makes, in whole or in part. The user agrees not to decompile, disassemble, decode, or reverse engineer any licensed program delivered to the user or any portion thereof.

Motorola reserves the right to make changes to any software or product to improve reliability, function, or design.

Motorola does not assume any product liability arising out of, or in connection with, the application or use of any product, circuit, or application described herein.

No license is granted, either expressly or by implication, estoppel, or otherwise under any Motorola, Inc., intellectual property rights. An implied license only exists for equipment, circuits, and subsystems contained in Motorola products.

MOTOROLA and the Stylized M Logo and Symbol and the Symbol logo are registered in the US Patent & Trademark Office. Bluetooth is a registered trademark of Bluetooth SIG. Microsoft, Windows and ActiveSync are either registered trademarks or trademarks of Microsoft Corporation. All other product or service names are the property of their respective owners.

Motorola, Inc.  
One Motorola Plaza  
Holtsville, New York 11742-1300  
<http://www.motorola.com/enterprisemobility>

---

## Warranty

For the complete Motorola hardware product warranty statement, go to:  
<http://www.motorola.com/enterprisemobility/warranty>.

---

## Revision History

Changes to the original manual are listed below:

Change	Date	Description
-01 Rev A	9/2009	Initial release
-02 Rev A	5/2010	Add Power-over-Ethernet (POE) information, remove instructions involving Initial Program Loader (IPL)



# Table of Contents

## About This Guide

Introduction .....	ix
Configurations .....	ix
Chapter Descriptions .....	ix
Notational Conventions .....	x
Related Publications .....	xi
Service Information .....	xi

## Chapter 1: MK4000 Introduction

Overview .....	1-1
MK4000 Parts .....	1-1
Touch Screen LCD .....	1-1
Speakers .....	1-1
Microphone .....	1-1
Scanner Window .....	1-2
External Ports .....	1-3
MK4000 Features .....	1-4
Bar Code Scanner/Imager .....	1-4
Software .....	1-4
Touch Screen .....	1-4
Memory .....	1-4
Connectivity Options .....	1-4
Micro SD Card Slot .....	1-4
Power .....	1-4
Magnetic Stripe Reader (Optional) .....	1-4
Mounting Options .....	1-5
Symbol Mobility Developer Kits (SMDKs) .....	1-5
Bar Code Decoding .....	1-6
Scanning with the MK4000 .....	1-6
Imaging with the MK4000 .....	1-8

**Chapter 2: Installation**

Overview .....	2-1
Unpacking the MK4000 .....	2-1
Removing the Screen Protector .....	2-2
Inserting a Micro SD Card .....	2-2
Connecting the MK4000 .....	2-2
AC Power Supply .....	2-2
USB Connection .....	2-3
Wired Ethernet Connection .....	2-3
MK4000 Mounting .....	2-5
Using a VESA Mount .....	2-5
Using the MK4000 Wall Mount Kit .....	2-6
Using the MK4000 Pole Mount Kit .....	2-7
Magstripe Reader Installation .....	2-9
Card Swiping .....	2-11
Advertisement Insert Mounting .....	2-12

**Chapter 3: Configuration**

Overview .....	3-1
System Configuration Manager .....	3-1
File Types .....	3-1
User Interface .....	3-2
File Deployment .....	3-4
Local Configuration Using the Microsoft Windows Control Panel .....	3-4
Configuration via Registry File .....	3-4
Rebooting the MK4000 .....	3-4

**Chapter 4: System Features**

Overview .....	4-1
RegMerge and CopyFiles .....	4-2
Accessing the Windows® CE Desktop .....	4-2
Network Time Update: SNTP Client .....	4-2
Memory Management .....	4-2
Flash: Nonvolatile (Persistent) Memory .....	4-2
RAM: Volatile (Non-Persistent) Memory .....	4-2
Browser Applications .....	4-3
Loading Additional Fonts on the MK4000 .....	4-3
Using Additional Fonts in Native Applications .....	4-4
Using Additional Fonts in Managed Applications .....	4-4
Using Additional Fonts in Browser Applications .....	4-4
Things to Consider when Using Additional Fonts .....	4-4
Input Panel (Virtual Keyboard) .....	4-5
Microsoft Applications .....	4-5

**Chapter 5: Application Deployment**

Software Installation on Development PC .....	5-1
Enterprise Mobility Developer Kit (EMDK) for C .....	5-1



Enterprise Mobility Developer Kit (EMDK) for .NET .....	5-2
Enterprise Mobility Developer Kit (EMDK) for Java .....	5-2
Symbol PocketBrowser for the Web .....	5-3
Device Configuration Package .....	5-3
Platform SDK .....	5-3
Installing Enterprise Mobility Developer Kits .....	5-4
Installing Other Development Software .....	5-4
Deployment .....	5-4
ActiveSync .....	5-5
OS Update .....	5-7
Terminal Configuration Manager (TCM) .....	5-8
Rapid Deployment Client .....	5-17
AirBEAM Smart .....	5-17
Flash Storage .....	5-18
FFS Partitions .....	5-18
Working with FFS Partitions .....	5-18
Non-FFS Partitions .....	5-19
Downloading Partitions to the MK4000 .....	5-19

## Appendix A: Technical Specifications

Technical Specifications .....	A-1
--------------------------------	-----

## Appendix B: Wireless Configuration

Overview .....	B-1
Wireless Applications .....	B-2
Signal Strength Icon .....	B-3
Turning the WLAN Radio On and Off .....	B-3
Find WLANs Application .....	B-4
Profile Editor Wizard .....	B-6
Profile ID .....	B-6
Operating Mode .....	B-7
Ad-Hoc .....	B-9
Security Mode .....	B-10
Authentication .....	B-11
Tunneled Authentication .....	B-12
User Certificate Selection .....	B-15
Server Certificate Selection .....	B-16
Encryption .....	B-21
IP Address Entry .....	B-25
Transmit Power .....	B-27
Battery Usage .....	B-29
Manage Profiles Application .....	B-30
Manage Certificates .....	B-33
Certificate Properties .....	B-33
Import a Certificate .....	B-34
Delete a Certificate .....	B-34
Manage PACs .....	B-35
PAC Properties .....	B-35

Delete PAC .....	B-35
Wireless Status Application .....	B-36
Signal Strength Window .....	B-37
Current Profile Window .....	B-38
IPv4 Status Window .....	B-39
Wireless Log Window .....	B-40
Versions Window .....	B-41
Wireless Diagnostics Application .....	B-41
ICMP Ping Window .....	B-42
Graphs .....	B-42
Trace Route Window .....	B-43
Known APs Window .....	B-44
Options .....	B-45
Operating Mode Filtering .....	B-45
Regulatory Options .....	B-46
Band Selection .....	B-46
System Options .....	B-47
Auto PAC Settings .....	B-47
Change Password .....	B-48
Export .....	B-49
Cold Boot Persistence .....	B-50
Registry Settings .....	B-51
Log On/Off Application .....	B-51
User Already Logged In .....	B-51
No User Logged In .....	B-52

## Appendix C: Troubleshooting

Overview .....	C-1
Troubleshooting Notes .....	C-1
Troubleshooting .....	C-1
MK4000 Version Information .....	C-4

## Appendix D: MK4000 Demo

Overview .....	D-1
Price Check #1 .....	D-1
Price Check #2 .....	D-2
Special Order Pick Up .....	D-2
Loyalty Coupon Printing .....	D-3
Loyalty Coupon Redemption (Mailer) .....	D-3
Cell Phone Coupon .....	D-3
Lottery Win Verification .....	D-4
Employee Application .....	D-4

## Index

Tell Us What You Think...

# About This Guide

---

## Introduction

The *MK4000 MicroKiosk for CE .NET 5.0 Product Reference Guide* provides information on installing, operating, and programming the MK4000.

✓ **NOTE** Unless otherwise noted, the term MK4000 refers to all configurations of the device.

---

## Configurations

This guide includes the following configurations:

- MK4000-0K0PZ0GWTWR - Imager, Ethernet
- MK4000-0U0PZ0GWTWR - Laser scanner, Ethernet
- MK4090-0K0PZ0GWTWR - Imager, 802.11 a/b/g
- MK4090-0U0PZ0GWTWR - Laser scanner, 802.11 a/b/g

---

## Chapter Descriptions

Following are brief descriptions of each chapter in this guide.

- [Chapter 1, MK4000 Introduction](#) provides an overview of the MK4000 that includes parts of the MK4000, features, and scanning modes.
- [Chapter 2, Installation](#) describes the hardware setup and installation of the MK4000.
- [Chapter 3, Configuration](#) describes the configuration parameters of the MK4000.
- [Chapter 4, System Features](#) describes the wide range of capabilities used to support independent application development on the MK4000.
- [Chapter 5, Application Deployment](#) describes the software development environments and how to install and upgrade applications and images.

- [Appendix A, Technical Specifications](#) provides technical information about the MK4000.
- [Appendix B, Wireless Configuration](#) describes how to configure the Spectrum24 wireless connection.
- [Appendix C, Troubleshooting](#) provides troubleshooting procedures for correcting problems encountered with the MK4000.
- [Appendix D, MK4000 Demo](#) provides information on the MK4000 demo which illustrates device functions.

---

## Notational Conventions

This document uses these conventions:

- “User” refers to anyone using an application on the terminal.
- “Device” refers to the MK4000.
- *Italics* are used to highlight specific items in the general text, and to identify chapters and sections in this and related documents. It also identifies names of windows, menus, menu items, and fields within windows.
- **Bold** identifies buttons to be tapped or clicked.
- Bullets (•) indicate:
  - lists of alternatives or action items.
  - lists of required steps that are not necessarily sequential.
- Numbered lists indicate a set of sequential steps, i.e., those that describe step-by-step procedures.



**NOTE** This symbol indicates something of special interest or importance to the reader. Failure to read the note will not result in physical harm to the reader, equipment or data.



**CAUTION** This symbol indicates that if this information is ignored, the possibility of data or material damage may occur.



**WARNING!** This symbol indicates that if this information is ignored the possibility that serious personal injury may occur.

---

## Related Publications

Following is a list of documents that provide additional information about configuring the MK4000:

- *MK500/MK4000 Quick Reference Guide*, p/n 72-112230-xx
- *MK4000 Platform Software Development Kit (PSDK)*
- *Enterprise Mobility Developer Kit (EMDK) for C*
- *Enterprise Mobility Developer Kit (EMDK) for .NET*
- *Enterprise Mobility Developer Kit (EMDK) for .WEB*
- *Microsoft Applications for Mobile and Win CE 5.0 User Guide*, p/n 72E-78456-xx
- *Symbol Application Guide for Symbol Devices*, p/n 72E-68901-xx
- *AirBEAM<sup>®</sup> Package Builder Product Reference Guide*, p/n 72-55769-xx.
- *AirBEAM<sup>®</sup> Smart Windows<sup>®</sup> CE Client Product Reference Guide*, p/n 72-63060-xx
- *MSP 3.X User's Guide*, p/n 72E-100158-xx

For the latest version of these guides and software, visit: <http://www.motorola.com/enterprisemobility/support>

---

## Service Information

If you have a problem with your equipment, contact Motorola Enterprise Mobility support for your region. Contact information is available at: <http://www.motorola.com/enterprisemobility/contactsupport>.

When contacting Enterprise Mobility support, please have the following information available:

- Serial number of the unit
- Model number or product name
- Software type and version number

Motorola responds to calls by e-mail, telephone or fax within the time limits set forth in service agreements.

If your problem cannot be solved by Motorola Enterprise Mobility Support, you may need to return your equipment for servicing and will be given specific directions. Motorola is not responsible for any damages incurred during shipment if the approved shipping container is not used. Shipping the units improperly can possibly void the warranty.

If you purchased your Enterprise Mobility business product from a Motorola business partner, please contact that business partner for support.



# Chapter 1 MK4000 Introduction

---

## Overview

The MK4000 MicroKiosk provides retail consumers access to data critical to making an informed purchasing decision. The MK4000 verifies prices on bar coded merchandise and obtains up-to-the-minute information on in-store promotions. Its easy-to-read display can be used as an electronic billboard for instant in-store merchandising and multimedia presentations to promote seasonal sales and upcoming events. The touch screen and programmable function buttons enhance in-store applications and allow customer interaction.

---

## MK4000 Parts

MK4000 parts include:

- Touch screen
- Speakers
- Scanner window
- External ports.

See [Figure 1-1 on page 1-2](#) and [Figure 1-2 on page 1-3](#) for illustrations.

## Touch Screen LCD

The full color 12.1 inch diagonal full X VGA (1024 X 760 pixels) or SVGA (800 X 600 pixels) LCD is ideal for presenting text, graphics, and video. The touch screen accommodates greater user interaction and enhances custom designed applications.

## Speakers

The MK4000 speakers are ideal for multimedia applications.

## Microphone

The MK4000 includes a microphone built into its front housing.

## Scanner Window

The scanner window protects the scan engine.

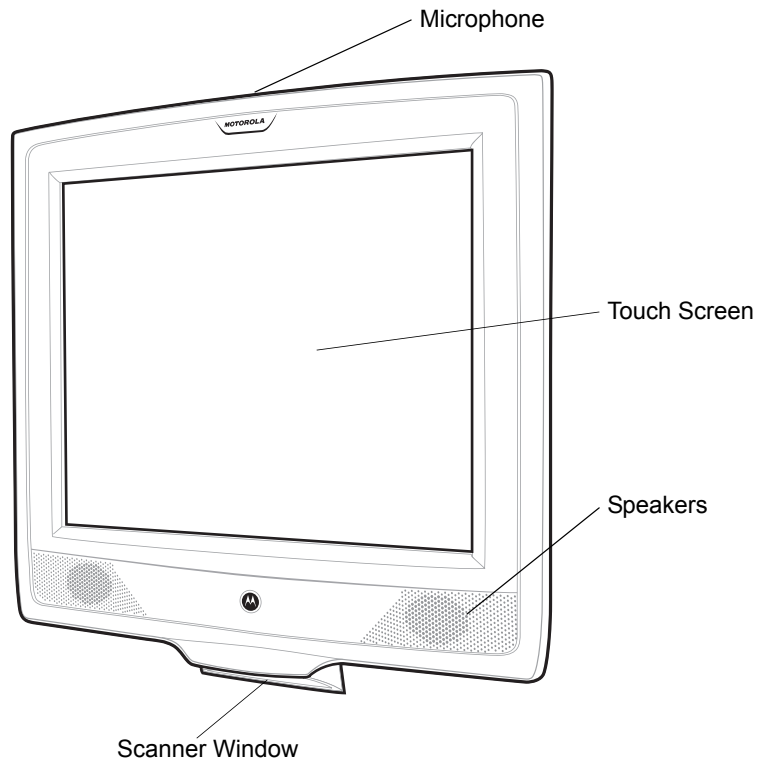

**Figure 1-1** *MK4000 Front View*



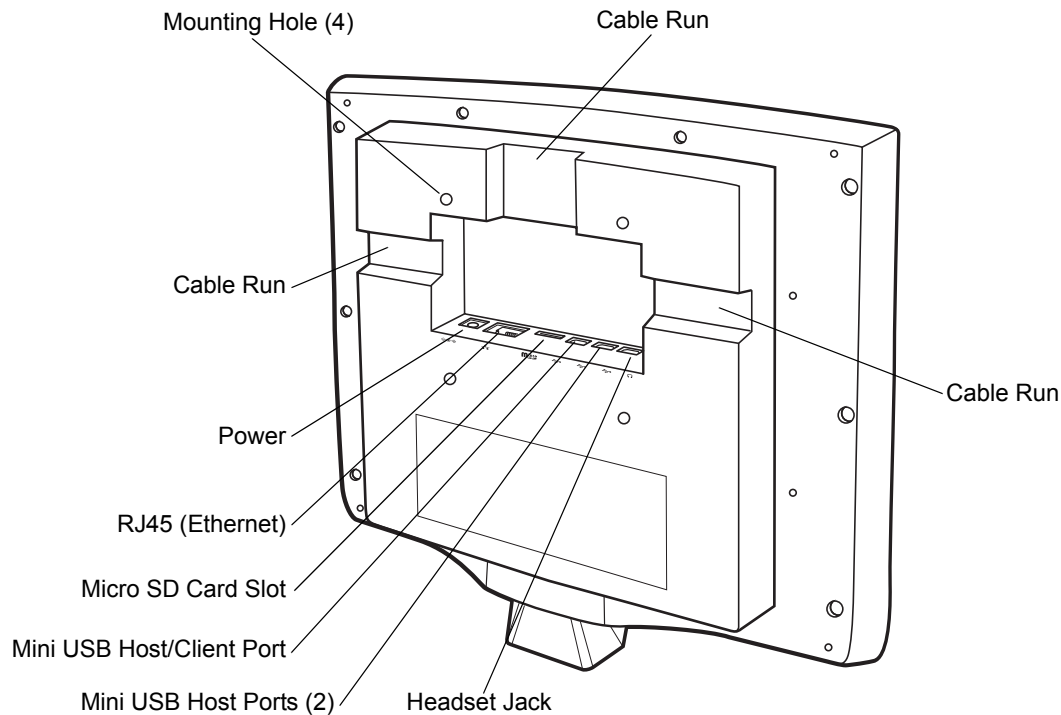

**Figure 1-2** MK4000 Rear View

## External Ports

The MK4000 has the following external ports:

### Power Port

A Symbol power supply connects to the power port (2.0 mm barrel jack connector) on the MK4000. For more information, see [AC Power Supply on page 2-2](#).

### Mini USB Ports

The MK4000 includes a Mini USB 1.1 host/client port and two Mini USB 1.1 host ports for peripheral connections. For more information, see [USB Connection on page 2-3](#).

### RJ45 Ethernet/Bias-T

#### ***Wired/Wireless Ethernet: Power through AC Outlet***

The Ethernet / Bias-T (10-conductor RJ45) port accommodates Ethernet data connection. The MK4000 receives power through the Symbol approved power supply.

#### ***Wired Ethernet: Power through Power-over-Ethernet***

The MK4000 supports Power-over-Ethernet (POE), 802.3at standard. An Ethernet (10/100Base-T) cable connected to the Ethernet port provides both data communication and power to the MK4000.

## Headset Jack

The MK4000 includes a port for headset connection.



**CAUTION** When connecting a headset, Motorola recommends using cable ties or other securing mechanisms outside the unit to provide strain relief.

---

## MK4000 Features

### Bar Code Scanner/Imager

The laser-based MK4000 decodes all traditional 1D bar codes (including RSS bar code type). The imager-based version decodes 1D bar codes as well as 2D symbologies such as PDF417. See [Bar Code Decoding on page 1-6](#).

### Software

Standard well-supported operating system and development tools ease application development for the Microsoft® Windows® CE .NET operating system: Embedded Visual C/C++ 4.0, Visual Studio.NET, Internet Explorer 6.0, C#, VisualBasic.NET, and Windows CE Media Player.

### Touch Screen

The touch screen provides user interaction and enhances the capabilities of custom applications.

### Memory

The MK4000 standard system configuration contains 128 MB flash/128 MB DRAM. The flash memory is non-volatile and stores the system firmware, user applications, and data.

### Connectivity Options

MK4000 connectivity options include USB, wired 10/100 Mbps Ethernet, or wireless 802.11 a/b/g Mbps.

### Micro SD Card Slot

The MK4000 contains a slot for micro SD cards of up to 8 GB.

### Power

To supply power, use the standard Symbol approved power supply or 802.3at Power-over-Ethernet certified equipment.

### Magnetic Stripe Reader (Optional)

An optional three-track Magnetic Stripe Reader (MSR) module attaches to the MK4000 and adds the ability to read and process loyalty card and credit card transactions. The MSR connects via USB to the MK4000.

## Mounting Options

You can mount the MK4000 on a desktop or wall using a commercially-available bracket or stand that conforms to the 100 mm VESA Flat Panel Monitor Physical Mounting Interface (FPMPMI™) mounting standards. See [MK4000 Mounting on page 2-5](#).

## Symbol Mobility Developer Kits (SMDKs)

The following developer kits are available for the MK4000:

- EMDK for C (see [Enterprise Mobility Developer Kit \(EMDK\) for C on page 5-1](#)) for developing native C/C++ applications
- EMDK for Java (see [Enterprise Mobility Developer Kit \(EMDK\) for Java on page 5-2](#)) for developing Java-based applications
- Symbol PocketBrowser (see [Symbol PocketBrowser for the Web on page 5-3](#)) for web development
- EMDK for .NET (see [Enterprise Mobility Developer Kit \(EMDK\) for .NET on page 5-2](#)) for developing managed .NET applications in C# or VB.NET.

---

## Bar Code Decoding

The MK4000 decodes any traditional retail 1D or PDF417 (imager-based only) bar code presented in its field of view.

### Scanning with the MK4000

When scanning a bar code using the laser-based MK4000:

- Hold the bar code at an angle which does not cause specular reflection (see [Specular Reflection on page 1-7](#)).
- Hold the bar code close for small bar codes and farther away for large bar codes.
- The MK4000 beeps to indicate a successful decode.

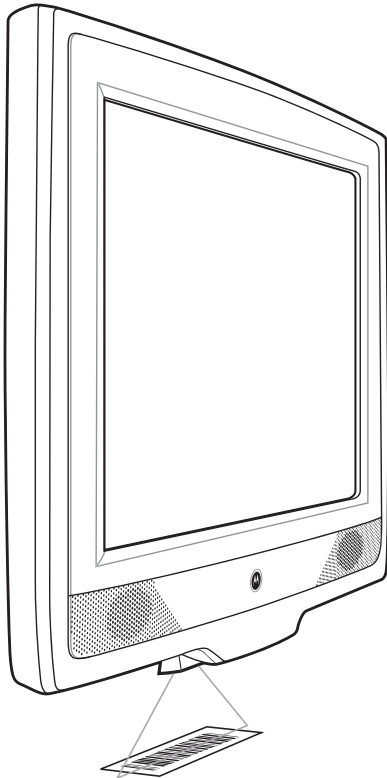

**Figure 1-3** Scanning with the MK4000

The scan beam does not have to be *perfectly* parallel with the top and bottom of the symbol (up to a 4° tilt is permitted). Ensure the symbol is in good condition.

## Specular Reflection

When laser beams reflect *directly* back into the scanner from the bar code, they can “blind” the scanner and make decoding difficult. This phenomenon is called specular reflection.

To avoid this, scan the bar code so that the beam does not bounce *directly* back. But do not scan at too oblique an angle; the scanner needs to collect scattered reflections from the scan to make a successful decode. Practice quickly shows what tolerances to work within.

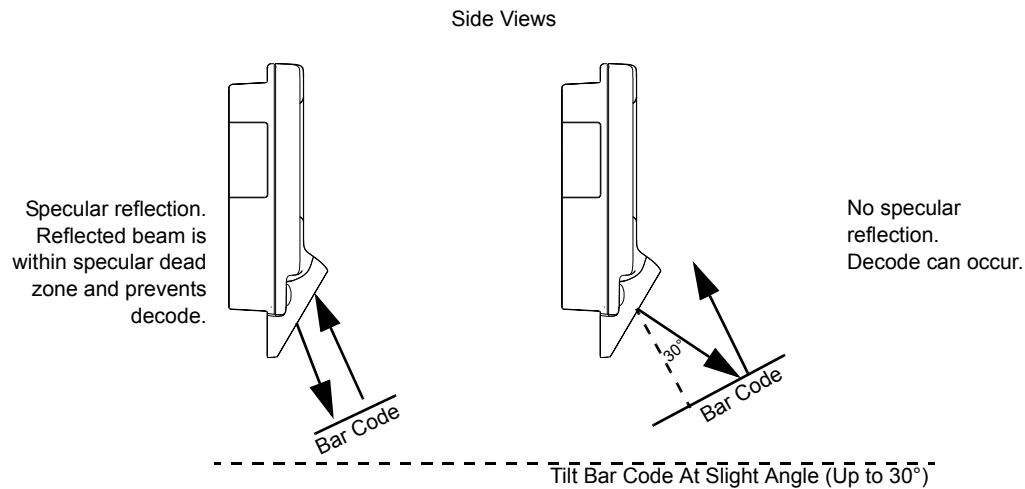

**Figure 1-4** *Avoiding Specular Reflection*

When scanning a 1D bar code, there is only a small specular dead zone to avoid ( $\pm 2^\circ$  from the direct laser beam). However, the scanner is not effective if its beams hit the bar code surface at an angle greater than  $30^\circ$ .

## Imaging with the MK4000

When imaging, ensure the bar code is within the decode range and within the aiming pattern. The MK4000 beeps to indicate a successful decode.

Place the symbol in any orientation within the aiming pattern. Ensure the entire symbol is within the rectangular area formed by the brackets in the aiming pattern. The red laser aiming pattern turns on to assist in aiming.

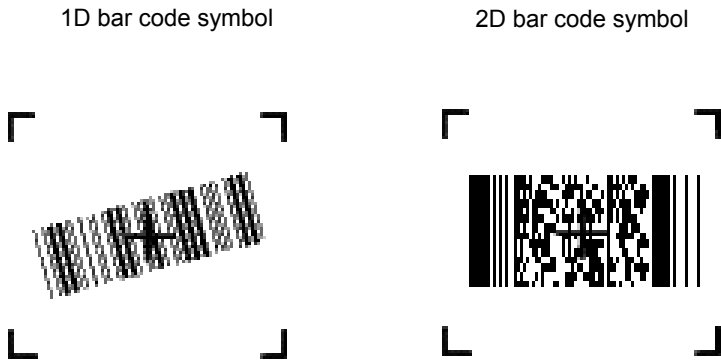

**Figure 1-5** *Imager Aiming Pattern: Bar Code Centered*

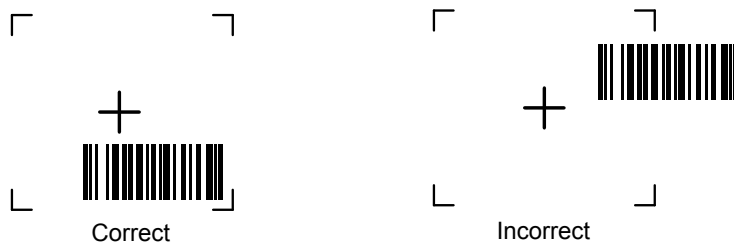

**Figure 1-6** *Imager Aiming Pattern: Bar Code Not Centered*

# Chapter 2 Installation



---

## Overview

This chapter describes MK4000 installation, including:

- Unpacking
- Mounting
- Inserting a micro SD card
- Providing power
- Connecting to a host
- Connecting peripherals
- Mounting the MK4000
- Magstripe reader installation
- Adding an advertising insert.

---

## Unpacking the MK4000

Remove the MK4000 from its packing and inspect it for damage. Keep the packing, it is the approved shipping container and should be used if the MK4000 needs to be returned for servicing.

---

## Removing the Screen Protector

A screen protector is applied to the MK4000. Motorola recommends using this to minimize wear and tear. Screen protectors enhance the usability and durability of touch screen displays.

To remove the screen protector, lift the corner using a thin plastic card, such as a credit card, then carefully lift it off the display.



**CAUTION** Do not use a sharp object to remove the protector. Doing so can damage the display.

For a package of five replacement screen protectors, contract Motorola.

---

## Inserting a Micro SD Card

To use a micro SD card, insert it into the slot in the back of the MK4000 as shown on the device. See [Figure 1-2 on page 1-3](#) for slot location. To remove the card, press down gently on it to eject, then remove it from the slot.

---

## Connecting the MK4000

The MK4000 communication interfaces include both wired or wireless solutions:

- USB Connection
  - Mini USB 1.1 host/client port - ActiveSync connection to a desktop computer
  - Two Mini USB 1.1 host ports for peripheral connections
- Wired Ethernet (10/100Base-T cable)
  - Power through AC outlet
  - Power through POE

To access the Windows® CE Desktop, see [Accessing the Windows® CE Desktop on page 4-2](#).

## AC Power Supply

The Symbol universal AC power supply connects to the power port on the MK4000 using a 2.0 mm barrel jack. The power supply has a positive center pin and the outer tab is ground. It is compatible with:

- 120V 60 Hz (North America)
- 230V 50 Hz (International excluding Japan)
- 100V 50/60 Hz (Japan).



## USB Connection

### Connecting to a Host

The MK4000 can communicate with a host using a mini B USB cable connected to the mini USB port.

1. Insert the power supply barrel connector into the MK4000 power port. See [Figure 1-2 on page 1-3](#).
2. Route the power cable.
3. Plug the Symbol AC power supply into a wall outlet.
4. Connect the USB cable to the mini USB port on the MK4000. See [Figure 1-2 on page 1-3](#) for port locations.
5. Connect the other end of the cable to a USB port on the host.

### Connecting to Peripheral Devices

Use a mini A USB cable and a USB adapter cable (available from Motorola) to connect to a peripheral device such as a printer, a handheld scanner, a keyboard, or mouse.

1. Connect the mini A USB cable to the mini USB port on the MK4000. See [Figure 1-2 on page 1-3](#) for port locations.
2. If necessary, connect the USB adapter cable to the mini A USB cable.
3. Connect the other end of the cable to the peripheral device.

## Wired Ethernet Connection

### Wired Ethernet: Power through AC Outlet

The MK4000 communicates to the host through a 10/100Base-T Ethernet cable and receives power through a Symbol AC power supply.

1. Insert the power supply barrel connector into the MK4000 power port. See [Figure 1-2 on page 1-3](#).
2. Route the power cable.
3. Plug the Symbol AC power supply into a wall outlet.
4. Connect the Ethernet cable to the RJ45 port on the MK4000. See [Figure 1-2 on page 1-3](#).
5. Plug the other end of the Ethernet cable into the host system LAN port.

### Wired Ethernet: Power through POE

The POE installation option allows the MK4000 to communicate and receive power on the same 10/100Base-T Ethernet cable.

1. Connect the Ethernet cable to the MK4000 RJ45 port. See [Figure 1-2 on page 1-3](#).
2. Plug the other end of the Ethernet cable into an 802.3at certified host system LAN port or 802.3at port injector.

## RJ45/Ethernet Connector Pinouts

[Figure 2-1](#) identifies the locations for the Ethernet port pins, and [Table 2-1](#) lists pin descriptions.

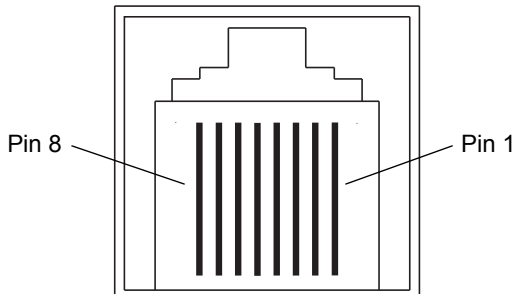

**Figure 2-1** 8-Pin RJ45 Connector Port

**Table 2-1** RJ45/Ethernet Pin Descriptions

Pin	Description
1	TXD (+)
2	TXD (-)
3	RXD (+)
4	Bias-T VCC
5	Bias-T VCC
6	RXD (-)
7	Bias-T GND
8	Bias-T GND

## MK4000 Mounting

To mount the MK4000 on a wall or counter top, use a mounting bracket that conforms to the 100 mm VESA specification. Also, Motorola offers an optional wall mount kit and pole mount kit for mounting the MK4000.

### Using a VESA Mount

To mount the MK4000 using a 100 mm VESA mounting bracket:

1. The device's mounting inserts are M4 x 8.1 mm. When selecting an appropriate screw type, ensure its length does not penetrate the device's back housing more than 8.1 mm after going through the mounting plate.
2. Align the VESA mounting holes with the mounting holes on the back of the device.
3. Insert the screws through each of the four aligned mounting holes.

*Figure 2-2* provides MK4000 dimensions for mounting reference.

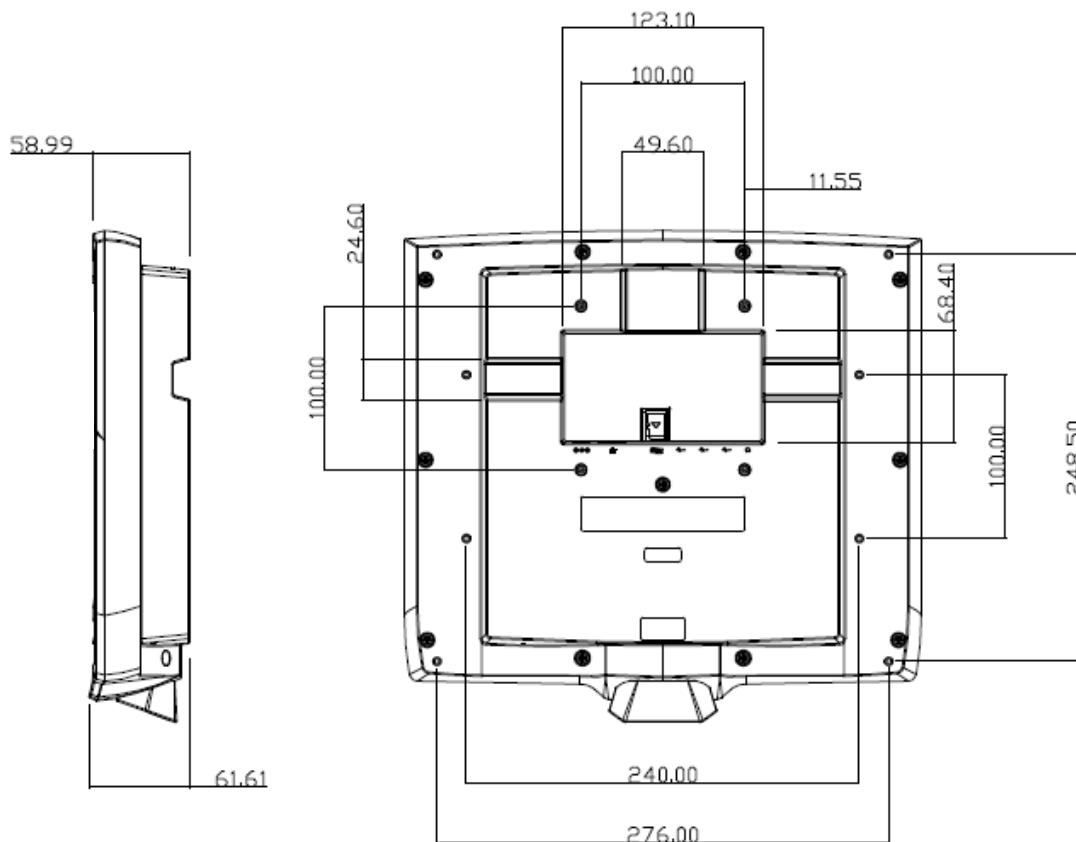
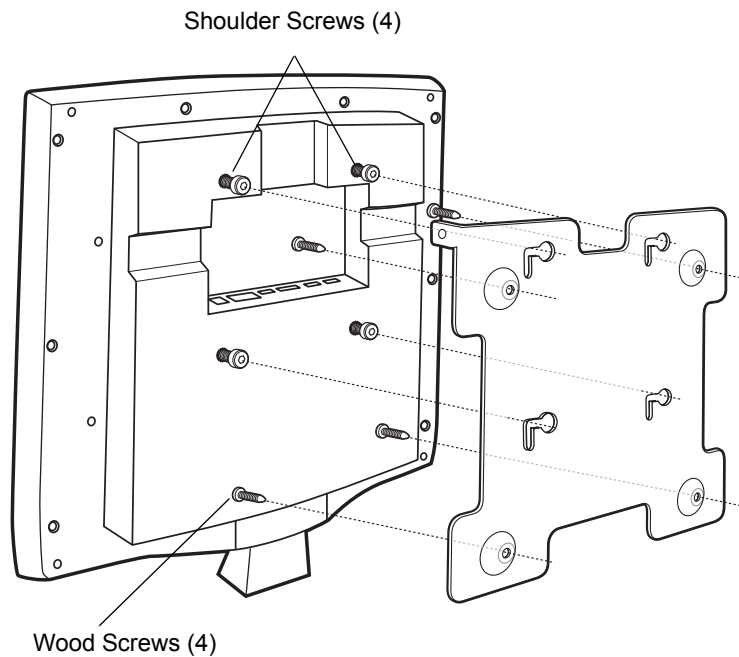

**Figure 2-2** MK4000 Mounting Dimensions

## Using the MK4000 Wall Mount Kit

To mount the MK4000 using the Wall Mount Kit:

1. Determine the MK4000 mounting location.
2. Secure the mounting plate to the wall using the four wood screws provided.
3. Insert the four shoulder screws, also provided, into the mounting holes in the back of the MK4000.



**Figure 2-3** MK400 Wall Mounting

4. Connect the cables to the MK4000 and route and secure them properly.
5. Mount the MK4000 by placing the shoulder screws through the four keyholes on the mounting plate, and slide the MK4000 down to secure in place.

6. Insert the locking screw through the hole in the tab at the side of the mounting plate. Hand tighten the screw to secure the MK4000.

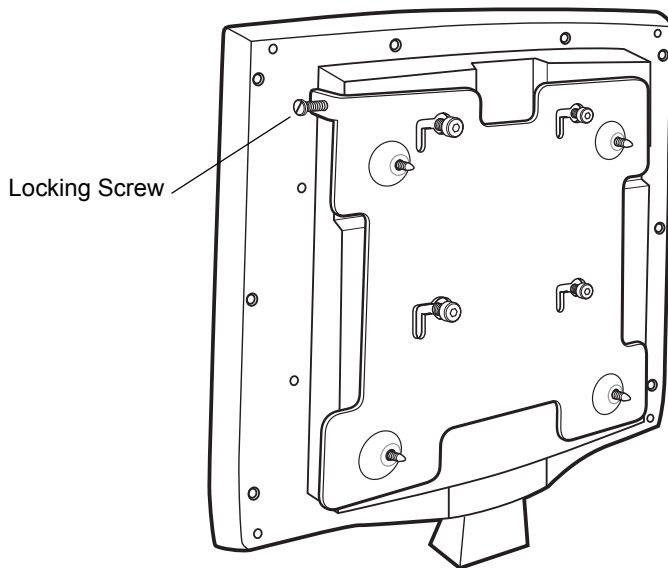

**Figure 2-4** MK4000 Wall Mount Locking Screw

## Using the MK4000 Pole Mount Kit

To mount the MK4000 to a pole using the Pole Mount Kit:

1. Connect the cables to the MK4000 and route and secure them properly.
2. Secure the mounting plate to the MK4000 using the four M4 panhead screws provided.
3. Insert the four shoulder screws into the mounting bracket.
4. Route the pole mount straps through the mounting bracket. Wrap them around the pole and tighten.
5. Mount the MK4000 by placing the four keyholes on the mounting plate over the shoulder screws on the mounting bracket, and slide the MK4000 down to secure in place.

6. Insert the locking screw through the hole in the bottom tab on the mounting bracket. Hand tighten the screw to secure the MK4000.

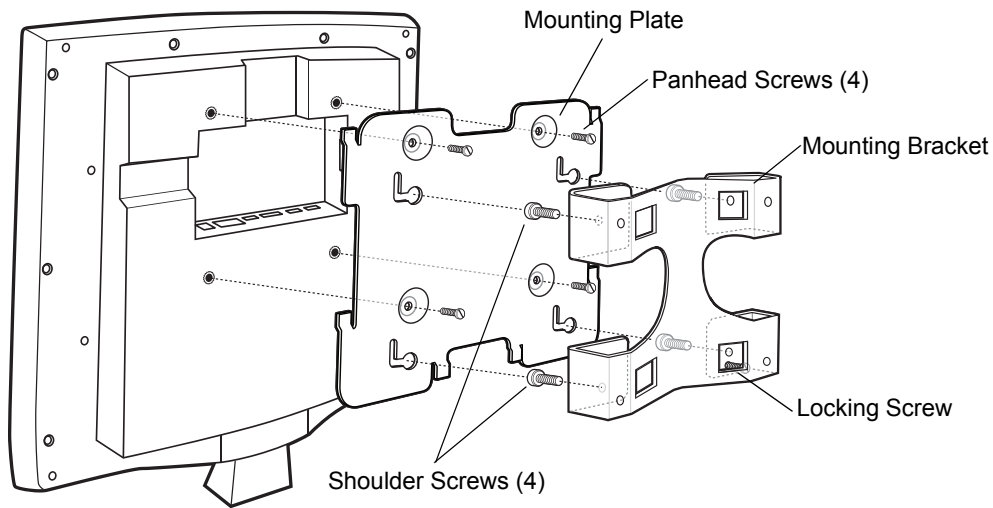

**Figure 2-5** MK4000 Pole Mount Installation

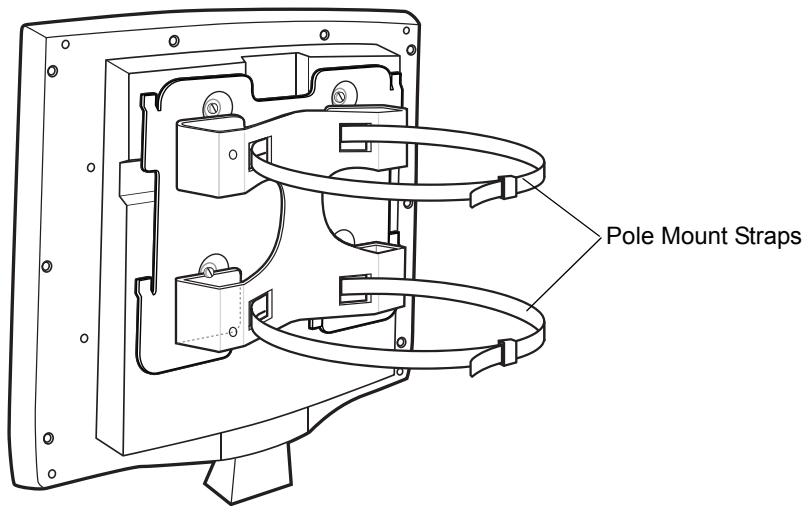

**Figure 2-6** MK4000 Pole Mount

---

## Magstripe Reader Installation

To install the optional MSR:

1. Secure the mounting plate to the MK4000 using the four screws provided.

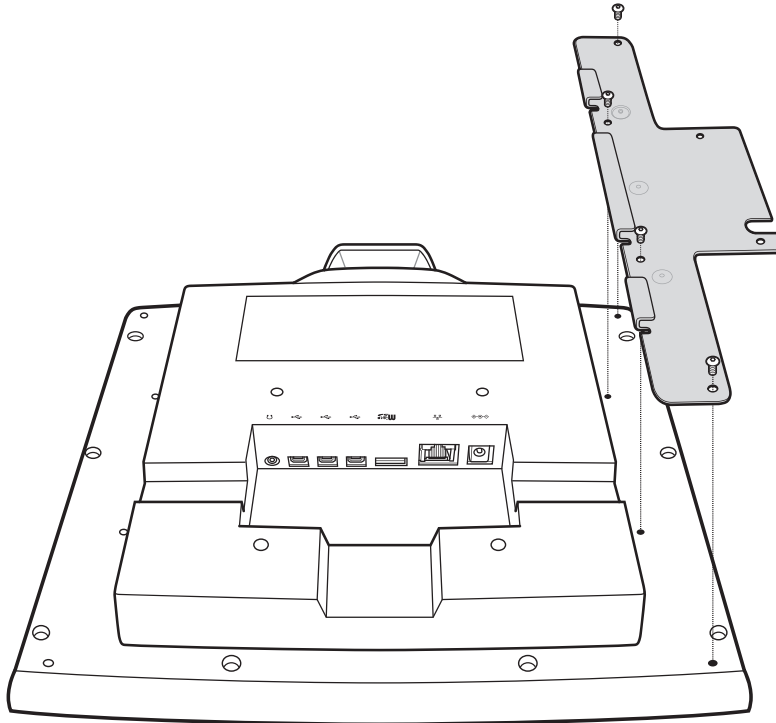

**Figure 2-7** *Securing the MSR Mounting Plate*

2. Secure the MSR to the plate using the two screws provided.

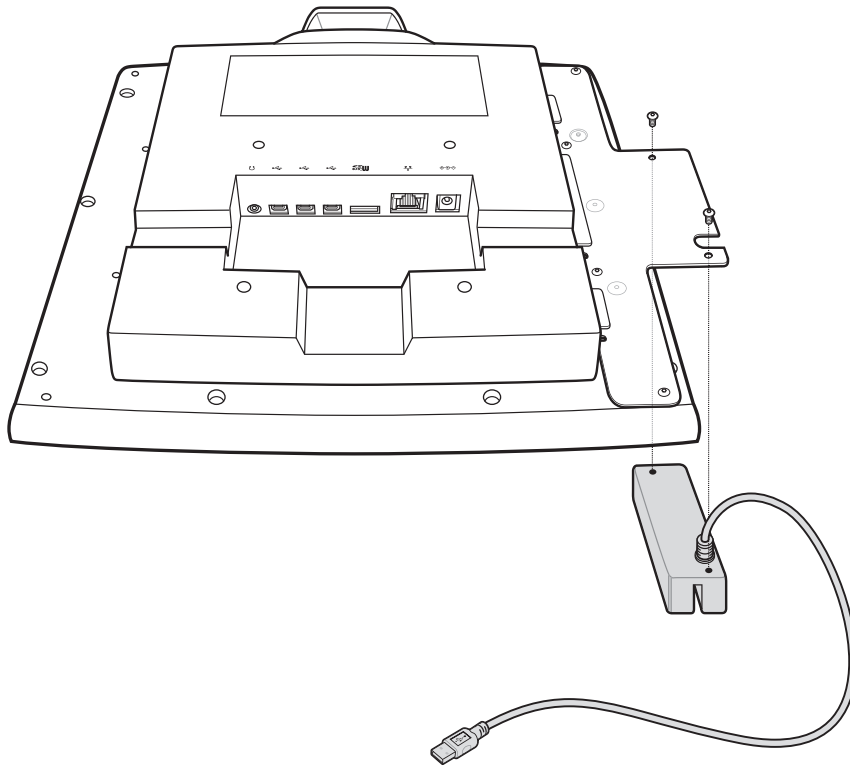

**Figure 2-8** *Securing the MSR to the Mounting Plate*

3. Connect the USB cable to one of the two mini USB host ports.

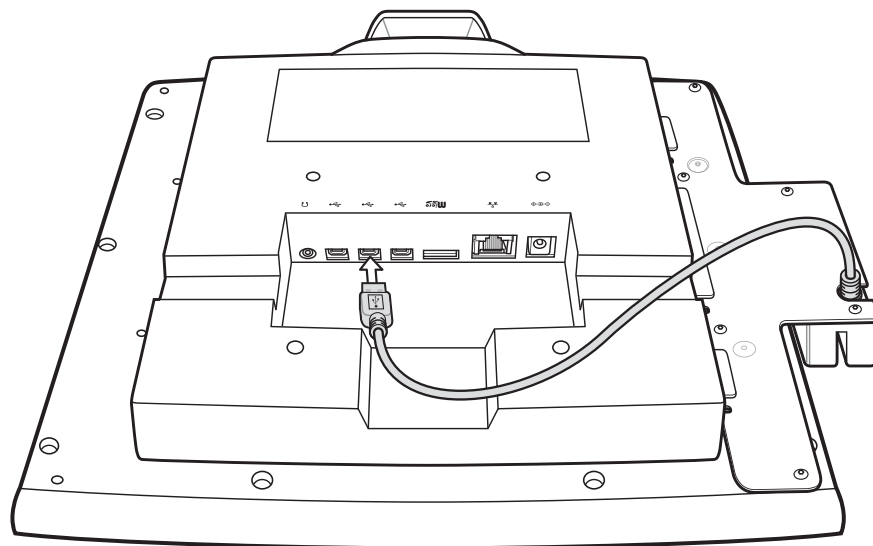
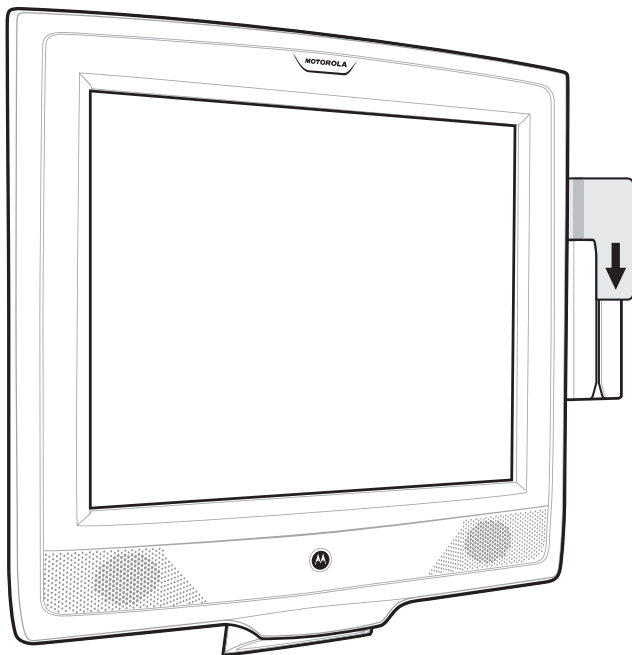

**Figure 2-9** *Connecting the USB Cable*



## Card Swiping

Swipe a card through the MSR in either direction, with the magnetic stripe facing in toward the MK4000.



**Figure 2-10** *Card Swiping*

## Advertisement Insert Mounting

Use an advertisement insert to attract customers to the MK4000. The recommended material for this is corrugated polyethylene. The internal dimensions of the insert must be 8.90 (226 mm) wide x 0.26" (6.5 mm) thick.

To install an insert:

1. Secure each of the two advertisement insert brackets to the back of the MK4000 using two of the provided pan head screws.

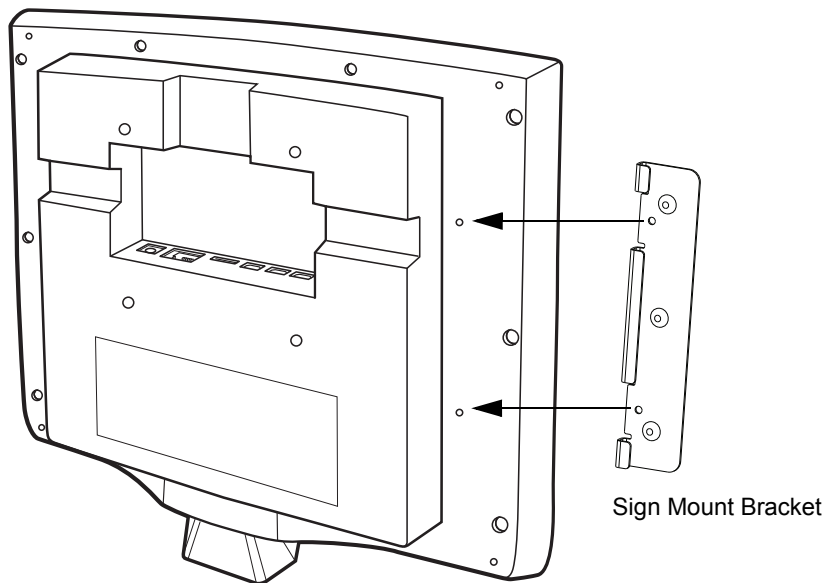

**Figure 2-11** Securing Sign Mount Brackets

2. Slide the insert into the bracket grooves on either side of the MK4000, and mount ads, signs, or instructions on this as needed.

✓ **NOTE** The optional MSR attachment accommodates signs so only one bracket is necessary.

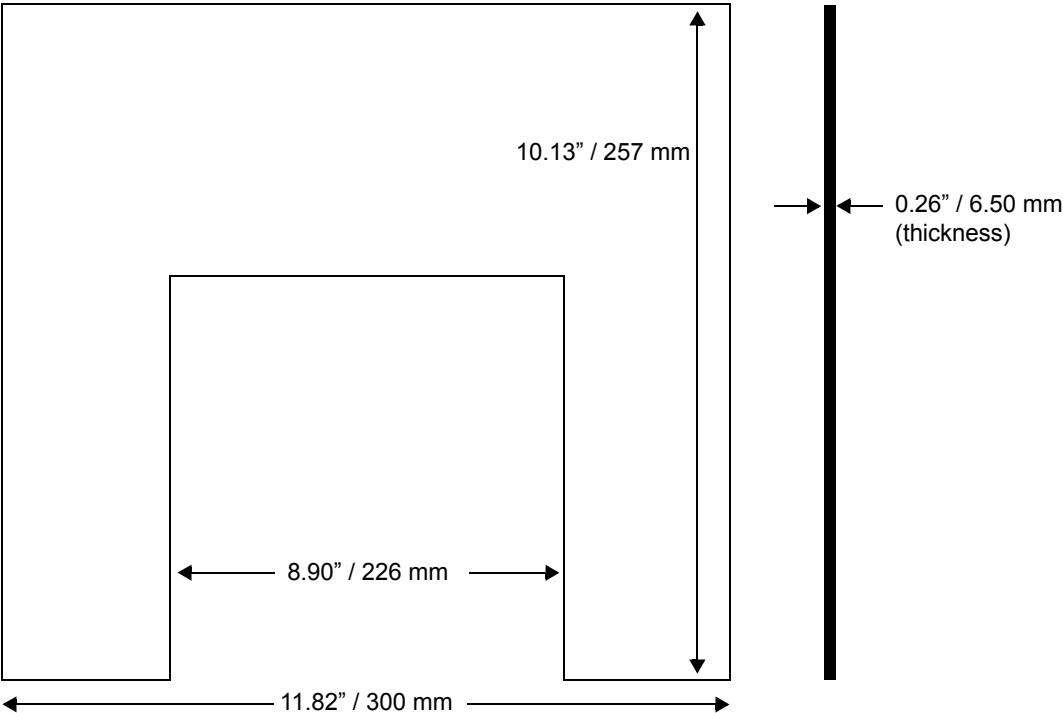

**Figure 2-12** *Advertisement Insert Dimensions*



# Chapter 3 Configuration

---

## Overview

This chapter describes how to set up and configure the MK4000 applications, communications, and network settings which include parameters such as the device name, internet browser settings, date and time, and several other key settings.

Configure these settings remotely using the System Configuration Manager (SCM), or locally on the MK4000 using the Control Panel. These settings are saved in the configuration registry file (mkconfig.reg) in the MK4000 Application folder to maintain them across cold boot cycles. For information on using the Control Panel, refer to the *Microsoft Applications for Mobile and Win CE 5.0 User Guide*.

---

## System Configuration Manager

The System Configuration Manager (SCM) is a Windows®-based utility that runs on a host computer and creates/edits an MK4000 configuration file (mkconfig.reg). Load this file onto the MK4000 and reboot the MK4000 to set configuration parameters for the device. The configurable options for the MK4000 are defined in an XML file that is available from Support Central at <http://www.motorola.com/enterprisemobility/support>. SCM is also available at Support Central.

SCM eliminates the potential user errors that occur when manually editing registry settings.

## File Types

SCM uses three types of files:

- Symbol Configuration Template (.SCT) files are XML files that define the configurable parameters for a device.
- Registry Configuration Service Provider XML files for device provisioning.
- CAB Provisioning Format (.CPF) file which is a .CAB archive that contains the provisioning XML. This file is downloaded to the MK4000 and merged upon a cold boot.

## User Interface

SCM's user interface consists of a tree control on the left side of the window which displays all the configuration categories, and a data grid table on the right which displays all the configurable controls for the selected category. [Figure 3-1](#) shows the main window for a device's .sct file.

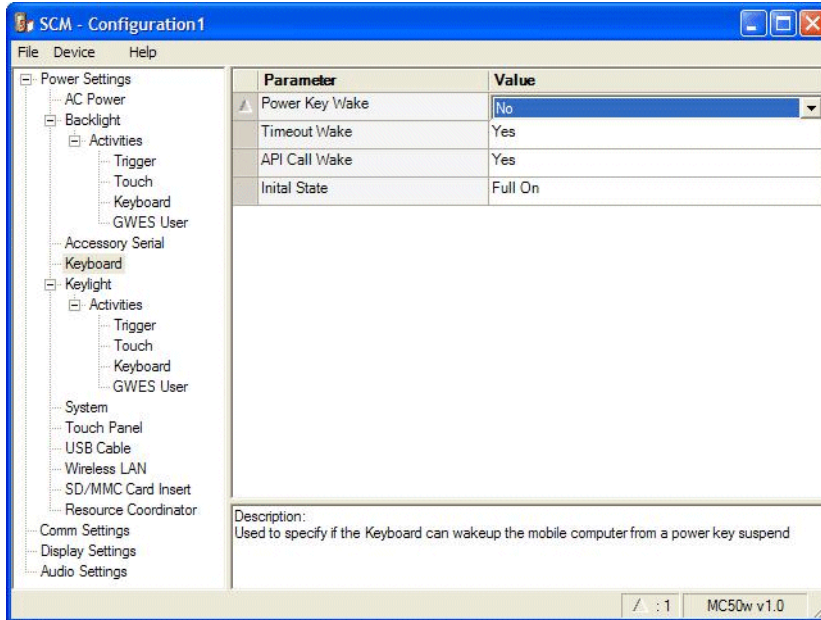

**Figure 3-1** Main SCM Window

## Menu Functions

Use the main menu to access the program functionality described in [Table 3-1](#).

**Table 3-1** SCM Menu Functions

Menu Item	Description
<b>File Menu</b>	
Open Config File	Open a saved configuration file (.SCD).
Save Config Changes	Save changes to the currently loaded configuration file.
Restore All Defaults	Restore all parameter values to the default state. The default values are stored in a Symbol Configuration template file.
Export Changes to .xml	Export the changed parameter values to an XML file.
Export Changes to .cpf	Export the changed parameter values to an CPF file.
Export all to .xml	Export all the parameter values to an XML file.
Export all to .cpf	Export all the parameter values to an CPF file.
Exit	Exit System Configuration Manager.



**Table 3-1** *SCM Menu Functions (Continued)*

Menu Item	Description
<b>Device Menu</b>	
Device type	Change the current device type template. Each template (available from Support Central) must reside in the SCM directory.
Help Menu	
About	Display the <b>About</b> dialog which shows the application version.

### Parameter State Indicators

The first column of the data table displays parameter state indicators. The state indicators display one of the states in [Table 3-2](#) for a particular parameter:

**Table 3-2** *Parameter Status Indicators*

Icon	Indicator	Description
	Modified	This parameter was changed from its initial factory setting.
	Invalid	This parameter is not valid for the selected device type. This can occur when a configuration file for one type of device is loaded and the device type is changed using the <b>Device</b> menu. Values marked “invalid” are not exported.

### Window Status Bar

The SCM status bar on the bottom right corner of the window contains the items in [Table 3-3](#) from left to right:

**Table 3-3** *Window Status Bar Items*

Status Bar Item	Description
Invalid Count	Number of parameters not valid for the selected device.
Modified Count	Number of parameters modified from the factory defaults.
Device Type	Device type - version.

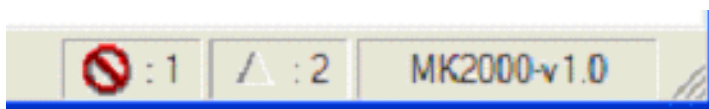
**Figure 3-2** *Sample Status Bar*

The sample status bar in [Figure 3-2](#) shows that the current configuration file contains 1 Invalid Parameter and 2 Modified Parameters.

## File Deployment

Deploy the CPF file created using the SCM export function to the MK4000.

1. Optionally, use the Authenticode tools to sign the .cpf file.
2. Make the .cpf file read-only, then copy it to the MK4000.
3. Tap the filename to install.
4. Certain applications and settings require a cold boot to take affect. In these cases, cold boot the MK4000. Refer to the *Windows Mobile Version 5.0 Help* file for more information.

For more information on file deployment, see [Deployment on page 5-4](#).

---

## Local Configuration Using the Microsoft Windows Control Panel

Use the Control Panel on the MK4000 Start menu to change settings locally. For information on using the Control Panel, refer to the *Symbol Application Guide for Symbol Devices*.

---

## Configuration via Registry File

Before downloading the configuration file (.reg file) to the MK4000 **Application** folder, rename it **mkconfig.reg**. Use one of the following methods to download the file to the MK4000:

- Copy the mkconfig.reg file to the MK4000 **Application** folder using a USB ActiveSync connection (see [Downloading Files to the MK4000 on page 5-6](#)).
- Send the file to the MK4000 **Application** folder using FTP (see the instructions provided with the FTP software) or AirBeam.
- Copy the mkconfig.reg file to an SD card, then transfer the file into the MK4000 **Application** folder.

## Rebooting the MK4000

After downloading the mkconfig.reg file, cold boot the MK4000 to apply the new settings.

### Cold Boot

Press and hold reset button on the side of the MK4000 for 10 seconds, then release, OR remove and apply power.

### Warm Boot

Run the Warmboot application. Select **Start > Programs > Warmboot**. Alternatively, use the Application Program Interface (API).



# Chapter 4 System Features

---

## Overview

This chapter discusses the following operating system features:

- [RegMerge and CopyFiles on page 4-2](#)
- [Accessing the Windows® CE Desktop on page 4-2](#)
- [Network Time Update: SNTP Client on page 4-2](#)
- [Memory Management on page 4-2](#)
- [Loading Additional Fonts on the MK4000 on page 4-3](#)
- [Input Panel \(Virtual Keyboard\) on page 4-5](#)
- [Microsoft Applications on page 4-5](#)

---

## RegMerge and CopyFiles

RegMerge and CopyFiles are two device drivers included in the Windows CE OS to assist developers in configuring the MK4000 following a cold boot. See [Flash Storage on page 5-18](#) for more information.

---

## Accessing the Windows® CE Desktop

If an MK4000 is configured to launch an application on power-up, you can bypass the application at boot-up to access to the Windows® CE desktop.

---

## Network Time Update: SNTP Client

The MK4000 Simple Network Time Protocol (SNTP) client can automatically set and update the MK4000 time and date through the network. Use this feature to set the system time and date after reboots or power outages. This feature also ensures consistent time and date stamping across a fleet of MK4000s. The SNTP Client program queries the specified SNTP server over the network to set the time and date.

The SNTP client shipped with MK4000 WinCE 4.20 is the Microsoft default SNTP Client program. (This is a change from the WinCE 4.1 operating system, which had a custom SNTP client).

---

## Memory Management

### Flash: Nonvolatile (Persistent) Memory

The MK4000 64 MB configuration has 64 MB of available nonvolatile flash memory. 5 MB is committed for platform partition use to install external driver packs such as RF drivers, and 27 MB is available for developer's applications within the application partition (folder). The data partition (folder) has no available memory. The data stored in flash memory persists through cold boot cycles.

To increase usable persistent (flash) memory, use the Terminal Configuration Manager (TCM) to adjust the allocation of memory between the application and data partitions. See [Chapter 5, Application Deployment](#).

Add a PC card to the MK4000 to increase the non-volatile memory available for file storage.

### RAM: Volatile (Non-Persistent) Memory

The MK4000 has 128 MB of DRAM volatile memory. Developers can automate control of the device's RAM (volatile) memory allocation (storage vs. memory used to run programs) to persist memory allocation settings through cold boot cycles.

---

## Browser Applications

The Symbol PocketBrowser 2.1 development tool allows Web developers to quickly create robust applications that can include a wide range of advanced data capture capabilities. The *Symbol PocketBrowser 2.1 Developer Help* provides information on using each feature of the browser. Each feature includes a sample, however the sample does not necessarily show the only way to implement each feature.

PocketBrowser extends the core rendering engine functionality of Microsoft PocketIE or Microsoft IE with Symbol application programming interfaces (APIs). It provides interfaces to device hardware and features using meta tags and Microsoft ActiveX<sup>®</sup> components designed specifically for Symbol systems. PocketBrowser offers easy integration with bar code scanners, RFID readers, and other peripherals such as printers and magnetic stripe readers (MSR) for complete transaction processing.

---

## Loading Additional Fonts on the MK4000

You can program the MK4000 to support additional fonts such as Unicode and double-byte character font.

The MK4000 supports the following system fonts as shipped from the factory. The font files corresponding to these formats are located in the **\windows** folder with .ttf extension.

- Arial
- Comic Sans MS
- Courier New
- Georgia
- Symbol
- Tahoma
- Times New Roman
- Verdana
- Wingding.

The default system font path for these fonts is **\windows**.

Use one of the following options to load fonts not supplied with the MK4000:

- Change the system font path where the system looks for fonts. For example, to change default system font path from **\windows** to **\application\fonts** add the following registry to the system along with new fonts in **\application\fonts**:

```
[HKEY_LOCAL_MACHINE\SOFTWARE\Microsoft\FontPath]
"FontPath"="\application\fonts"
```

Adding this registry changes the entire system fonts directory, so fonts supplied with the OS are no longer available. To use both the provided system fonts and new fonts, copy the system default fonts to the new font directory.

- Copy new/alternate fonts to the default **\windows** directory.
- Copy alternate fonts to the **\windows\fonts** directory.

Copying new fonts to the **\windows** or **\windows\fonts** preserves existing fonts. However the new fonts consume system RAM as they are part of the ObjectStore.

Using the third option, i.e., copying fonts to the \windows\fonts directory, makes it easier to manage the system. Note that fonts copied to \windows or \windows\fonts do not persist over power cycles or cold boots. Use the copy file feature to persist them over power cycles or cold boots.

## Using Additional Fonts in Native Applications

Any application written in EVC can use the additional fonts using either MFC or Win32 APIs. If a specified font is missing, the system uses an available font for display.

## Using Additional Fonts in Managed Applications

All fonts installed in the system are available to the .Net Compact Framework during runtime.

## Using Additional Fonts in Browser Applications

Regardless of how you installed the font in the system, to reference it using a browser page, specify the font as a STYLE, or use FONT tags. Use intuitive names for the fonts (use FontViewer on a Windows desktop and locate the **Typeface Name** line), and use quotes to enclose names with spaces. If the specified font is missing, Internet Explorer uses its default font to display the text.

## Things to Consider when Using Additional Fonts

- Different font styles (e.g., bold and italic) often require separate TTF files; be sure to provide all required styles. Do not reference styles by name (e.g., Arial Bold); set the style separately from the font (e.g., using a “b” or “strong” tag, or a style).
- For best results, do not direct the system font path to a storage card (PCMCIA), as this can negatively impact system performance. If this method is necessary, test the use of a storage card thoroughly for fonts to ensure proper operation.
- Most Web pages contain information that tells the browser what language encoding (the language and character set) to use. If the page does not include that information, and the Language Encoding Auto-Select feature is on, Internet Explorer can usually determine the appropriate language encoding. If not, manually select it using **View** menu > **Encoding** > **More**, then select the appropriate language.

✓ **NOTE** If the Auto-Select feature or a specific language pack is not installed, Internet Explorer prompts you to download the files. Adding languages does not guarantee Web pages display in the preferred language.

---

## Input Panel (Virtual Keyboard)

Use the input panel (virtual keyboard) on the touchscreen of the MK4000 to enter information.

To access the **Input Panel**, tap the  icon in the icon tray. To enter information, use a stylus to select the keys on the input panel. To close the **Input Panel**, double-tap the icon.

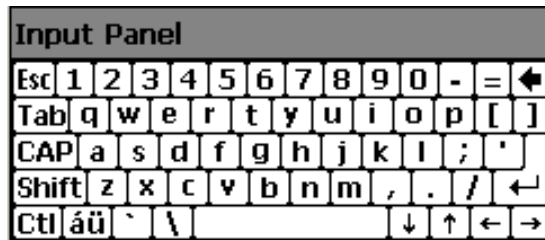

Figure 4-1 Input Panel (Virtual Keyboard)

✓ **NOTE** Use Ctrl-C to copy text, and Ctrl-V to paste text.

---

## Microsoft Applications

The MK4000 includes Microsoft WordPad, Windows Media Player, and Internet Explorer. For information on using these applications, refer to the *Microsoft Applications for Mobile and Win CE 5.0 User Guide*



# Chapter 5 Application Deployment

---

## Software Installation on Development PC

To develop applications to run on the MK4000, use one or all of the following:

- Enterprise Mobility Developer Kit (EMDK) for C for developing native C/C++ applications
- Enterprise Mobility Developer Kit (EMDK) for .Net for developing managed .NET applications
- Enterprise Mobility Developer Kit (EMDK) for Java for developing browser-based applications
- Symbol PocketBrowser for support for web development
- Device Configuration Package (DCP) for MK4000.

### Enterprise Mobility Developer Kit (EMDK) for C

The Enterprise Mobility Developer Kit for C is based on industry-standard Microsoft® Windows® CE development tools and enables development of native C and C++ applications. Use this developer kit in conjunction with Microsoft® Embedded Visual C++ 4.0 Service Pack 3 and MK4000 Platform Software Development Kit (PSDK).

EMDK for C includes the following components:

- Standard Symbol C API Libraries
- MK4000-specific C API Libraries
- Help file containing a C API Reference Guide
- Sample applications with full source code.

### Sample Applications

The sample applications are included as a learning tool, to show developers how to interface with the Symbol C API functions. Some of the sample applications contained in the kit include:

- **Hello:** A simple Hello World application.
- **DisplayTest:** Displays various colors on the LCD screen.
- **KeyCheck:** A keyboard checking utility that displays the keys pressed on the device and their associated WM\_MESSAGE.

- **ScanSamp2:** Demonstrates the bar code scan engine (and external scanner).
- **MSRSamp2:** Displays the MSR track data when a card is swiped.
- **MemTest:** Displays the amount of available memory. Allocate and free blocks of memory to see how available memory changes.
- **Win32PrintSamp:** Prints a sample page to a connected printer.

✓ **NOTE** The MK4000 supports the Signature Capture API via the EMDK for C only. Refer to the Enterprise Mobility Developer Kit version 1.4 or later, under MK Series C APIs - Signature Capture.

## Enterprise Mobility Developer Kit (EMDK) for .NET

The Enterprise Mobility Developer Kit for .NET allows Microsoft® .NET Compact Framework developers to create managed (C# and VisualBasic.NET) applications that harness value-add features on the MK4000. Use this developer kit in conjunction with the EMDK for C.

The EMDK for .NET includes the following components:

- Class libraries
- Sample applications
- Documentation describing how to use the methods for each class library

## Enterprise Mobility Developer Kit (EMDK) for Java

The Enterprise Mobility Developer Kit for Java enables development of browser-based applications written in VBScript or Jscript. Use this developer kit in conjunction with any web page editor such as Microsoft Front Page or Notepad. It contains the following components:

- Documentation for the Symbol ActiveX Object library \*
- Sample HTML/Jscript applications

\* The ActiveX objects are built into the MK4000 operating system and do not need to be loaded.

The MK4000 ships with Internet Explorer CE version 6.0 browser, which supports VBScript and Jscript. See <http://www.microsoft.com> for information on Internet Explorer CE version 6.0 features and limitations.

The MK4000 operating system also includes the KioskIE.exe browser, which runs in full screen mode without the browser toolbar.

ActiveX objects provide control over the scan engine (and external scanner), four programmable buttons, microphone, MSR, and printers. For information on loading alternate fonts onto the MK4000, see [Loading Additional Fonts on the MK4000 on page 4-3](#).

✓ **NOTE** MK4000 supports only the following Active X Objects/Controls: Printer, BarcodeReader, AudioManager, MKUtility, and MSR.



## Symbol PocketBrowser for the Web

The Symbol PocketBrowser is a web development kit that provides access to the functionalities of a Symbol device. The PocketBrowser is used across all vertical markets and in a wide variety of applications, enabling developers and integrators to provide advanced Web-based solutions for Motorola devices. Transfer a PocketBrowser application from one Motorola device to another seamlessly without recompiling or rewriting it.

PocketBrowser features include:

- Blocking users from the Microsoft operating system
- Exposing the full screen area to the Web application designer
- Seamless integration with bar code scanning
- Wireless connectivity
- Magnetic stripe readers.

## Device Configuration Package

Use the Device Configuration Package (DCP) to create and download hex images that represent flash partitions to the MK4000. The DCP includes the user documentation, flash partitions, Terminal Configuration Manager (TCM), and the associated TCM scripts.

To install the DCP for the MK4000:

1. Download the DCP from the Support Central web site, <http://www.motorola.com/enterprisemobility/support>:
  - a. On <http://www.motorola.com/enterprisemobility/support>, select *Software Downloads*.
  - b. Select *MicroKiosks* and then select *MK4000*.
  - c. Select the *Device Configuration Package (DCP)*.
  - d. Save the .exe file to the development computer.
2. Locate the .exe file on the development computer, double-click the file, and follow the install screen prompts.
3. Once installed, access the major components of the DCP from the *Symbol Device Configuration Package (DCP) for MK4000* program group of the *Windows Start Menu*.

## Platform SDK

To download and install the Platform SDK:

1. Download the appropriate Platform SDK from the Support Central web site, <http://www.motorola.com/enterprisemobility/support>:
  - a. On <http://www.motorola.com/enterprisemobility/support>, select *Software Downloads*.
  - b. Select *MicroKiosks* and then select *MK4000*.
  - c. Select the *Platform SDK*.
  - d. Save the .exe file to the development computer.
2. Run the file and follow the screen prompts to install.

## Installing Enterprise Mobility Developer Kits

To install an EMDK:

1. Download the EMDK from <http://www.motorola.com/enterprisemobility/support>
  - a. On <http://www.motorola.com/enterprisemobility/support>, select *Developer Downloads* and sign in.
  - b. Select *MicroKiosks* and then select *MK4000*.
  - c. Select the latest version of the *Enterprise Mobility Developer Kit*.
  - d. Download the .exe file to the development computer.
2. Double-click the executable file and follow the install screen prompts.

## Installing Other Development Software

Developing applications for the MK4000 may require installing other development software such as application development environments on the development PC. Follow the installation instructions provided with this software.

---

## Deployment

With the appropriate accessory, software, and connection, the MK4000 can share information with the host device. This chapter provides information about installing software and files on the MK4000.

Download and install software using one of the following methods:

- ActiveSync (see [page 5-5](#))
- OS Update (via SD card) (see [page 5-7](#))
- Terminal Configuration Manager (TCM) (see [page 5-8](#))
- FTP server using Rapid Deployment (see [page 5-17](#))
- AirBEAM (see [page 5-17](#)).

## ActiveSync

The MK4000 communicates with a host computer using Microsoft® ActiveSync (version 4.5.1 or higher). Use USB ActiveSync to transfer data between a host computer and the MK4000. The ActiveSync software on the MK4000 allows copying and pasting (rather than synchronizing) files between the MK4000 and host computer.

### Installing ActiveSync

To install ActiveSync on the host computer, download the latest version of the software from <http://www.microsoft.com>. Refer to the installation instructions included with the ActiveSync software.

### Connecting the MK4000 to the Host Computer

To configure ActiveSync for Guest access (suitable for copying files between the host computer and the MK4000):

1. Connect the USB cable to the mini USB port on the MK4000 (see [Figure 1-2 on page 1-3](#)). Connect the other end of the cable to a USB port on the host computer.
2. If the **New Partnership** window does not appear, on the host computer, select **Start > Programs > Microsoft ActiveSync**.

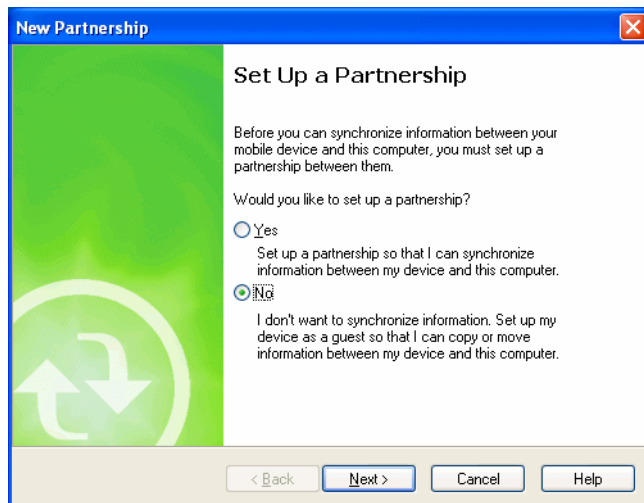

Figure 5-1 *New Partnership Window*

3. Click **No** and then **Next**. The **Microsoft ActiveSync Guest Connected** window displays.

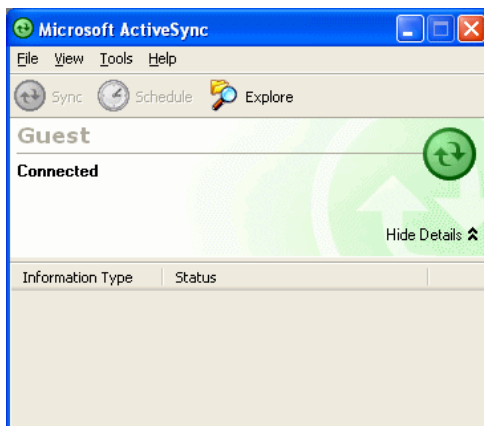

Figure 5-2 *Microsoft ActiveSync Guest Connected Window*

## Downloading Files to the MK4000

To download files (such as the mkconfig.reg file) from the host computer to the MK4000, use Windows Explorer to copy the files:

1. On the host computer, select **Explore**.

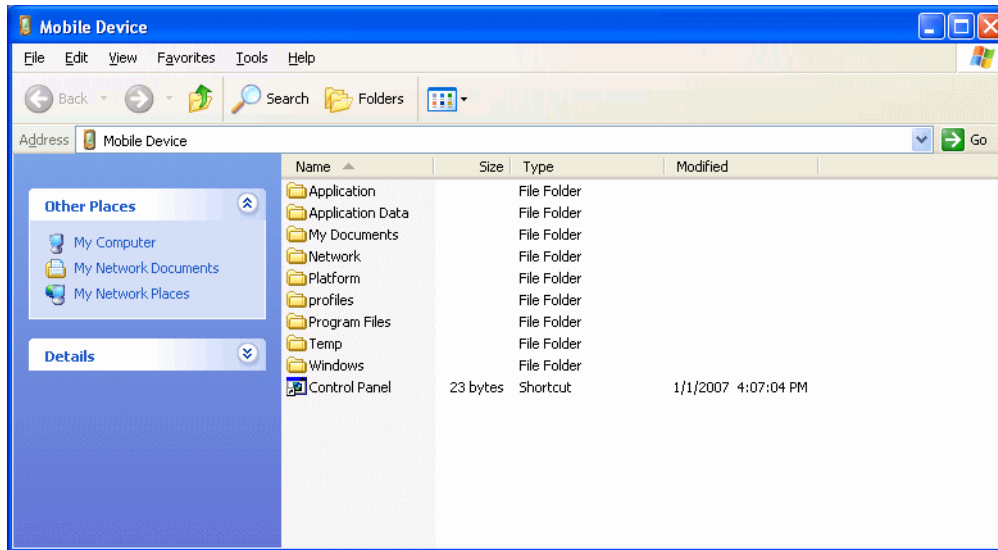

Figure 5-3 ActiveSync Explorer

2. Double-click the folder to expand the contents of the folder.

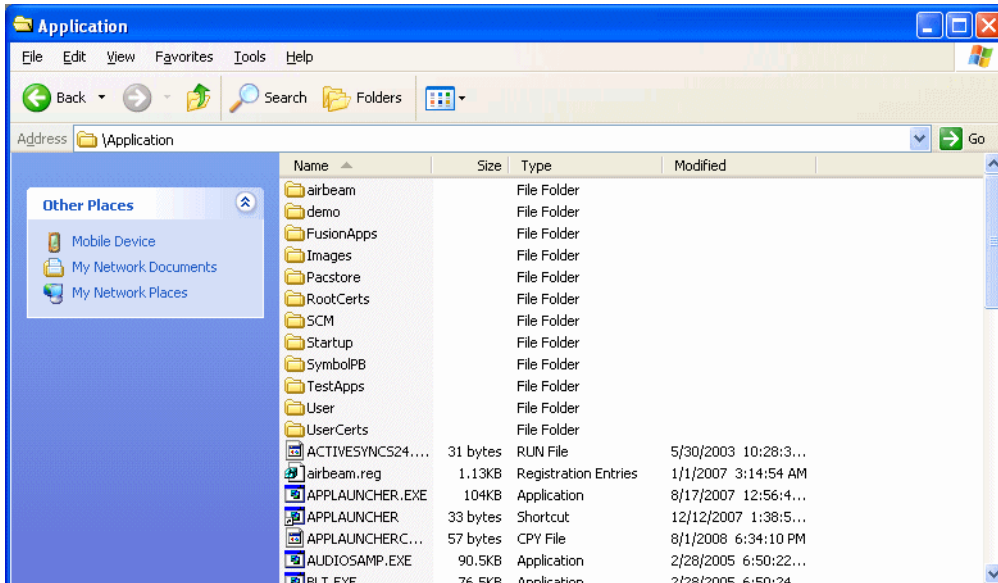

Figure 5-4 My Pocket PC Contents

3. Use Explorer to locate the host computer directory that contains the file to download. Tap that directory in the left pane to display its contents in the right pane.

4. Drag the desired file(s) from the host computer to the desired mobile device folder.
  - *Program Files* folder: files stored in this folder are discarded after a cold boot.
  - *Application* folder: files stored in this folder are retained after a cold boot.

✓ **NOTE** Cold booting the MK4000 erases all files in RAM. Be sure to save any critical files in the Application folder, e.g., radio profile, time zone setting, license keys. See [Downloading Files to the MK4000 on page 5-6](#).

## OS Update

To upgrade the operating system using an SD card,

1. Install the DCP onto the desktop computer.

✓ **NOTE** If you use a firewall, the firewall may prevent some files from installing. To verify that the DCP installation completes, ensure the following folder contains files, and is not empty:  
<Your drive:>\Program Files\Symbol Device Configuration Package\MK4000c50\<version number folder>\OSUpdate\Images.

2. Insert an SD card with at least 16 MB of storage into the MK4000. See the [Inserting a Micro SD Card on page 2-2](#).
3. Connect the MK4000 to power and to the desktop computer via a USB cable, and set up a partnership between the two computers using ActiveSync. See [ActiveSync on page 5-5](#).
4. In the *ActiveSync* window on the desktop computer, select **Explore**.
5. On the drive in which you installed the DCP (typically C:), navigate to the directory:  
\Program Files\Symbol Device Configuration Packages\MK4000c50\V1.0\
6. Copy the OSUpdate folder into the My Device\SC Card\ folder on the MK4000.
7. On the MK4000, tap **Start > Programs > Windows Explorer**.
8. Navigate to \SD Card\OSUpdate folder.
9. Double-tap the *MK4000c50BenColor\_SD.LNK* file.
10. After the update completes and the MK4000 reboots, remove the SD card.

## Terminal Configuration Manager (TCM)

Terminal Configuration Manager (TCM) is an application that runs on the host computer and customizes flash file system partitions for the MK4000. The most common use is to create an application partition hex file that contains the customer's application. Also use TCM to load hex files to the flash memory of the MK4000.

TCM scripts control the customization of partitions. The scripts contain all the information for building an image. The script is a list of copy commands specifying the files to copy from the development computer to the partition.

TCM works with a pair of directory windows, one displaying the script and the other displaying the source files on the development computer. Use standard Windows drag-and-drop operations to add and delete files from the script window.

The DCP for MK4000 includes scripts Motorola uses to build the standard factory-installed *Platform* and *Application* partitions on the MK4000. The standard *Platform* partition contains drivers and the *Application* partition contains demo applications and optional components. The standard TCM scripts are in the following folder:  
*C:\Program Files\Symbol Device Configuration Packages\MK4000 v1.0\TCM Scripts.*

✓ **NOTE** Before creating a script to build a hex image, identify the files required (system files, drivers, applications, etc.) and locate the files' source directories to ease the script building process.

The processes for building a hex image in TCM include:

- Starting TCM
- Defining script properties
- Creating the script for the hex image
- Building the image
- Download the hex image to the MK4000
- Creating a splash screen
- Flash storage.

### PC Download

Use the developer cable (p/n 25-119283-01R) with TCM to download hex configuration files to the MK4000, to download customized flash file system partitions to the MK4000, and load hex files to the flash memory of device.

A typical partition is a group of files, combined into a single "partition" that represents a specific area of storage. Examples of partitions are the flash file systems such as Platform or Application. (Using the desktop computer comparison, these partitions are roughly equivalent to a C: or D: hard disk drive.) In addition to the "hard disk" partitions, some partitions are used for single items such as the operating system, monitor, or splash screen. (Again using a desktop computer comparison, these partitions are roughly the equivalent of the BIOS or special hidden system files.) Updating a partition erases all data previously in its storage region, i.e., it is not a merge but a replacement operation.

## Starting TCM



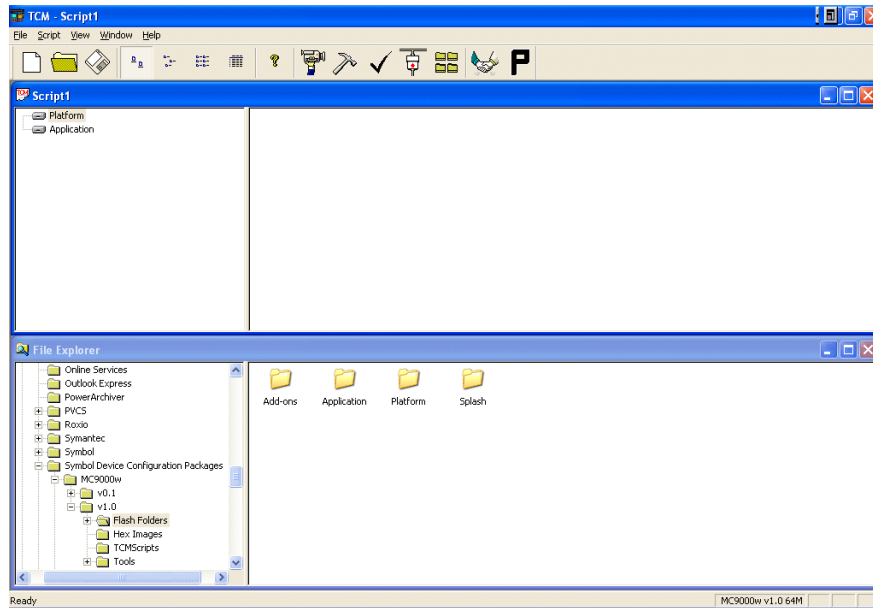





Click the Windows start menu TCM icon (*Symbol Device Configuration Packages, MK4000*) to start TCM. The **TCM** window displays two child windows: **Script1** and **File Explorer**. The **Script1** window contains a new script and the **File Explorer** window contains a file explorer view for selecting files to place in the script.











**Figure 5-5** TCM Startup Window

[Table 5-1](#) lists the components of the TCM window.

**Table 5-1** TCM Components

Icon	Component	Function
	Script Window	Displays the files to use in creating the partition(s).
	File Explorer Window	Lists the files to add to the script.
	Create button	Creates a new script file.
	Open button	Opens an existing script file.
	Save button	Saves the current script file.
	Large icons button	Views the current script items as large icon.
	Small icons button	Views the current script items as small icon.
	List button	Views the current script items as a list.
	Details button	Views the current script items with more details.

**Table 5-1** TCM Components (Continued)

Icon	Component	Function
	About button	Displays version information for TCM.
	Properties button	Views/changes the current script properties.
	Build button	Builds the current script into a set of hex files.
	Check button	Checks the script for errors (files not found).
	Send button	Downloads the hex image to the vehicle computer.
	Tile button	Arranges the sub-windows in a tiled orientation.
	Build and Send	Builds the current script into a set of hex images and sends the hex images to the device.
	Preferences button	Views/changes global TCM options.

## Defining Script Properties

Before creating a script, define the script properties, such as the type of device, flash type, number of disks being created, and the memory configuration of each disk partition.

To define the script properties:

1. Select the **Script** window to make it active.
2. Click the **Properties** button. The **Script Properties** window > **Partition Data** tab appears.

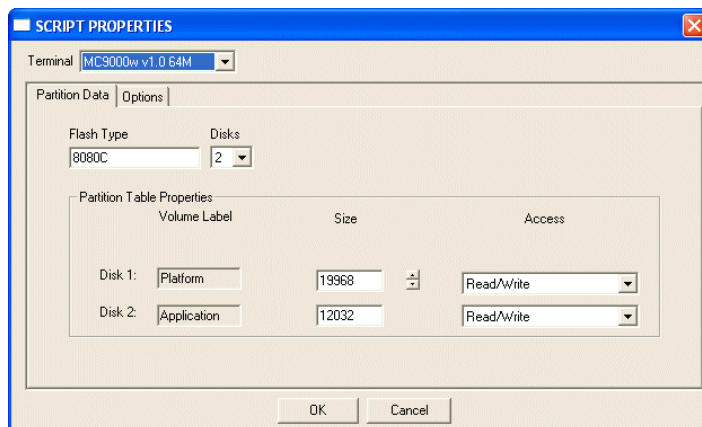
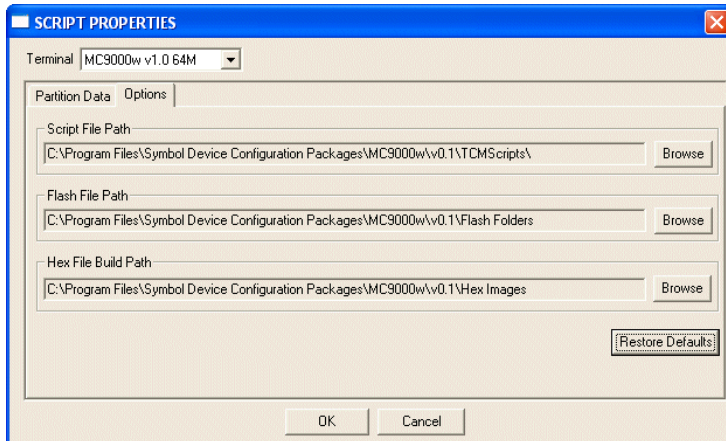

**Figure 5-6** Script Properties Window - Partition Data Tab

3. In the **Terminal** drop-down list, select the terminal type.
4. Use the default **Flash Type**.
5. In the **Disks** drop-down list, select the number of disk partitions to create.



6. Select the (memory) **Size** for each partition. Note that adding space to one disk partition subtracts it from another.
7. In the **Access** drop-down list for each disk partition, determine and select the Read/Write access option.
8. Click the **Options** tab. The **Script Properties** window **Options** tab appears.



**Figure 5-7** Script Properties Window - Options Tab

9. Set the paths for the Script File, Flash File, and Hex File Build.
10. Click **OK**.

### Creating the Script for the Hex Image

On start-up, TCM displays the TCM window with the **Script1** window and **File Explorer** window pointing to the following directory:

```
\Program Files\Symbol Device Configuration Packages\MK4000\TCMScripts\
```

The *Script1* window directory pane displays two partitions: *Platform* and *Application*. Depending on the type of flash chip, the number of partitions can change. You can add files to each of the partitions. TCM functionality includes:

- Opening a new or existing script file
- Copying components to the script window
- Saving the script file.

### Opening a New or Existing Script

You can create a script file from scratch or based on an existing script file. Click **Create** to create a new script or click **Open** to open an existing script (for example, a script provided in the DCP for MC40x0c). If you open an existing script and make changes, saving the changes overwrites the original script. To use an original or Motorola supplied standard script as a base and save the changes in a new script, use the **Save As** function to save the script using a different file name.

### Updating TCM 1.X Scripts

You can upgrade script files created with older versions of TCM to TCM 2.0 scripts. Click **Open** to open an existing script created with an older version of TCM. The *Conversion* window appears.

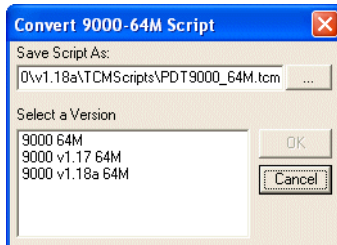

**Figure 5-8** Conversion Window - Upgrading to TCM 2.0

### Copying Components to the Script

Script contents are managed using standard file operations such as **New Folder**, **Delete** and **Rename**. Items can be added to the script by clicking files and folders in the **File Explorer** window and dragging them to the **Script** window. The **File Explorer** window supports standard windows; multiple files may be selected by clicking while holding the **SHIFT** or **CTRL** keys.

### Saving the Script

Modifications to a script file can be saved using the **Save** or the **Save As** function. Saving changes to an existing script writes over the original script. To use a Motorola-supplied standard script as a base and save the changes in a new script, use the **Save As** function.

### Building the Image

After creating the script, build the hex image defined by the script.

As part of the build, TCM performs a check on the script which verifies that all files referenced in the script exist. This check is important for previously created scripts to ensure that files referenced in the script are still in the designated locations.

To build scripts:

1. Click **Build** on the TCM toolbar. The **Configure Build** window appears.

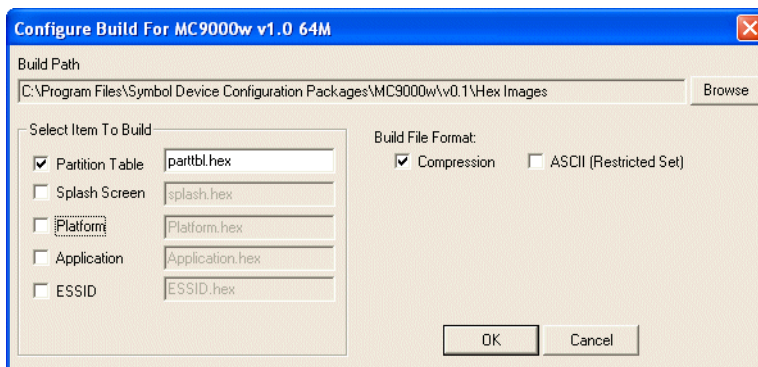
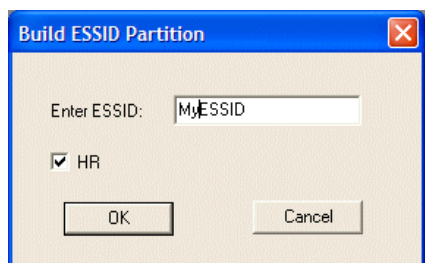

**Figure 5-9** Configure Build Window

2. Select the items (partitions) to build using the check box(es) to the left of each named partition.

3. Use the **Build Path** to define where to store all built partitions.
4. Select (hex image) COMPRESSION to reduce the size and speed up the download.
5. Click **OK** and follow the on-screen instructions.

If one of the partitions is the ESSID, a prompt appears requesting the ESSID value. Deselect the HR (High Rate) check box when building ESSID images for a device with an FH radio.



**Figure 5-10** *Build ESSID Partition Window*

If one of the partitions is the Splash Screen, a prompt appears requesting both the source Bitmap file and the destination HEX file.

6. TCM performs a check, and if there are no errors, creates the partition hex files.

If the build fails, TCM does not create the hex files and displays an error message. Two common reasons for a build failure are:

- TCM could not find the files defined in the script. This error can occur when the files referenced by the script are no longer stored on the development computer or the folders where they are stored were renamed.
- The total amount of flash memory space that the script requires exceeds the image size. To correct this, reduce the number of files in the partition or increase the size of the partition. See [Defining Script Properties on page 5-10](#) for more information about setting the image size appropriately.

## Downloading the Image

After building the hex file, download it to the MK4000 using the developer cable:

1. Remove power from MK4000.
2. Connect a DB9 cable to the RJ45 port on the MK4000, and the other end to the host computer.
3. Connect the developer cable to the mini USB host/client port (the mini USB port closest to the MicroSD card slot) on the MK4000.
4. Connect the other end of the developer cable to the USB port on the host computer.
5. On the host computer open a terminal emulation program such as Hyperterminal. Configure the selected port as follows:
  - Baud rate: 38400
  - Data bits: 8
  - Parity: None
  - Stop bits: 1
  - Flow control: None
6. Connect power to the MK4000. The download prompt `}}}` appears.

7. Press the **d** key on the host computer. The prompt **mon>** appears.
8. Enter the command:  
**d u: p=**  
then press the **Enter** key. The display indicates **Waiting for input...**
9. In TCM on the host computer, click **Load** on the toolbar. The **Load Terminal** window > **Serial** tab appears.

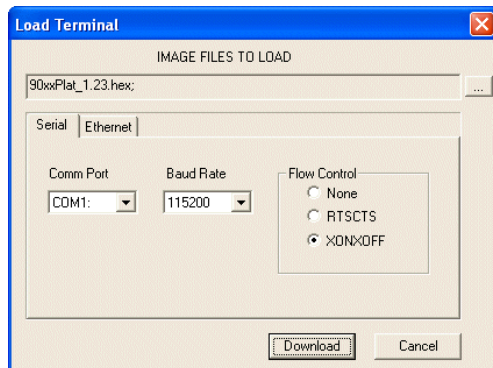

**Figure 5-11** Load Terminal Window - Serial and Ethernet Tabs

10. Select the **Image Files To Load**.
11. In the **Comm Port** drop-down list, select **USB: Symbol Device**.
12. Click **Download** to begin the operation. The **Downloading** screen on the MK4000 displays the **Device Status** and a progress bar.
13. When complete, **Device Status** displays **Result was: Success!**, or in the case of an error, the cause of the error.
14. When download completes, enter **reset** to reboot the MK4000.

## Calibrating the Screen

Use the **Calibration** screen to align the touch screen:

1. Remove and restore power to the MK4000 to reboot.

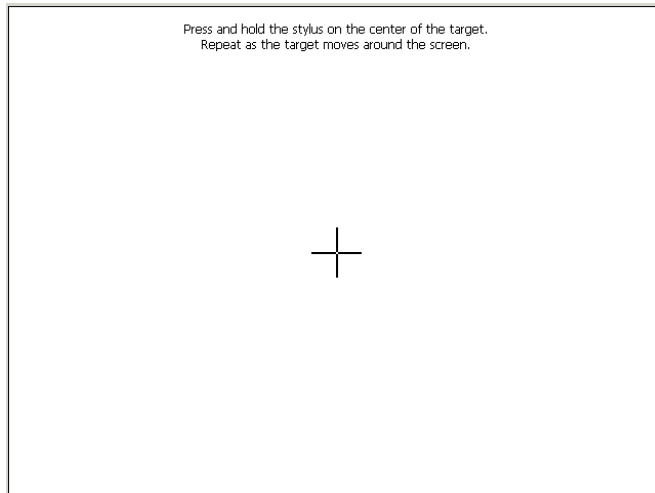

**Figure 5-12** Calibration Screen

✓ **NOTE** To access the **Calibration** screen from the Windows CE Control Panel, tap **Start > Settings > Control Panel**. Double-tap the **Stylus** icon, tap the **Calibration** tab, and tap the **Recalibrate** button. The **Calibration** screen appears.

2. Carefully press and briefly hold the stylus tip on the center of the **Calibration** screen target. Repeat the procedure as the target moves and stops at different locations on the screen.
3. The **Confirm Calibration** screen displays. Tap the screen to accept the settings, or wait 30 seconds and the MK4000 returns to the Calibration screen.

## TCM Error Messages

TCM validates the cells in the partition table when you click the **Execute** button. Cells highlighted in red contain an error. Partition loading is disabled until all errors are corrected.

**Table 5-2** TCM Error Messages

Error	Description/Solution
Failed to build images: flash file system DLL not loaded!	TCM could not load the DLL required to build images for the targeting flash file system. Reinstall TCM or recover the DLL.
Failure finding directory xxx	Building process failed because directory xxx was not found.
Failure creating volume	Building process failed because a certain disk volume could not be created.
Failure adding system file to image	Build process failed because TCM failed to add a certain system file to the disk image.
INVALID PATH	The path for the image file to build is not valid.
Nothing Selected To Build	In the Config Build window, no item is selected to build.

**Table 5-2** TCM Error Messages (Continued)

Error	Description/Solution
Illegal ESS ID	In the Build ESSID Partition window, no ESS ID was entered or the ESS ID entered was illegal.
Disk Full	TCM failed to create Hex image file at the selected path. Check available disk space.
Target Disk Full	Build process failed because TCM failed to add file to the image of a disk volume. Remove some files or increase the disk size.
Hex file is READ ONLY	The Hex image file to be created exists and is read-only. Delete the existing file or change its attribute.
Error opening the file xxx with write access	TCM could not open file xxx with write access. Check if file is in use.
Failure creating binary file	TCM failed to open/create an intermediate binary file.
Hex File To load is missing or invalid	In Load Terminal window, the file selected to load has invalid status.
Could not locate MK4000 name in TCM.ini file	While loading the Script Properties window, TCM could not find the TCM.ini section corresponding to the MK4000 type specified by the current opening script. Either TCM.ini or the script file is invalid.
Incorrect disk sizes in TCM.ini file	The total disk size specified in the script does not match the total disk size defined in the corresponding TCM.ini section. Check if the script is corrupt or the TCM.ini has changed after the script was created.
INVALID DIRECTORY	In Script Properties window, the selected System File Path is not a valid directory.
One of the disk sizes is one sector in size	In Script Properties window, one of the disks is too small (one sector in size). This may cause problem while building images, especially when cushion is enabled. Increase the disk size.
INVALID VOLUME NAME	In Script Properties window, one of the volume labels is not valid.
Corrupt TCM.INI file! (Invalid value of VolumeDivisor)	The VolumeDivisor entry is missing or invalid in the TCM.ini. Reinstall TCM or recover TCM.ini.
Invalid version of TCM script file	The TCM script was not created by this version of TCM.
Corrupt or missing TCM.ini file	TCM could not find TCM.ini file.
FAILED CONNECTION TO COM PORT (Could not get status)	While downloading images to MK4000, TCM failed to connect to the selected COM port. Check if the COM port is free and is properly configured.
FAILED CONNECTION TO TERMINAL (Terminal Not Connected Properly/Terminal Not Ready to Receive)	While downloading images, TCM failed to connect to the MK4000. Check if the correct flow control protocol is selected and the MK4000 is properly connected and is in a listening state.

## Creating a Splash Screen

The DCP for MK4000 includes the source bitmap files that create the default splash screens. You can customize the screen by modifying these files using any of the standard windows image editors.

To create a custom splash screen:

1. Use an image editor to open the Splashcolor.bmp file included with the DCP for MK4000.
2. Modify the bitmap file and save.
3. Create a splash partition. See [Building the Image on page 5-12](#).

If you don't use the default files to create the new splash screens, be sure to preserve the image format of 320 x 216, 8 bits per pixel. Note that 8 bits per pixel only applies to splash screen images. Once Windows CE is running, the color density is 16 bits per pixel. See [Downloading the Image on page 5-13](#) for information about loading the splash screen using TCM.

## Rapid Deployment Client

The Rapid Deployment (RD) Client facilitates software downloads to an MK4000 from a Mobility Services Platform (MSP) Console's FTP server. The MSP Console is a web-based interface to the wireless infrastructure monitoring and management tools provided by the MSP Lite or MSP Enterprise server.

When software packages transfer to the FTP server, an MK4000 on the wireless network can download them by scanning RD bar codes encoding the location of the software packages. Multiple MK4000s can scan a single RD bar code.



**NOTE** For detailed information about the Rapid Deployment Client and creating RD bar codes, refer to the *MSP 3.X User's Guide*.

## AirBEAM Smart

The AirBEAM Smart product transfers specially designed software packages between a host server and Motorola wireless device. Before transfer, AirBEAM Smart checks and compares package version, so that only updated packages load.

AirBEAM Smart resides on radio-equipped client devices and allows them to request, download, and install software, as well as to upload files and status data. A single communications session can accomplish both download and upload of files. The ability to transfer software over a radio network can greatly reduce the logistical efforts of client software management.

In an AirBEAM Smart system, a network-accessible host server acts as the storage point for the software transfer. The AirBEAM Smart Client uses the industry standard FTP or TFTP file transfer protocols to check the host system for updates and, if necessary, to transfer updated software.



**NOTE** For more information about AirBEAM Smart, refer to the *AirBEAM® Smart Windows® CE Client Product Reference Guide* and *AirBEAM Package Builder Product Reference Guide*.

---

## Flash Storage

In addition to the RAM-based storage standard on Windows CE devices, the MK4000 also includes a non-volatile Flash-based storage area which can store data (partitions) that a cold boot cannot corrupt. This Flash area is divided into two sections: Flash File System (FFS) Partitions and Non-FFS Partitions.

### FFS Partitions

The MK4000 includes two FFS partitions. These partitions appear to the MK4000 as a hard drive that the OS file system can write files to and read files from. Data is retained even if power is removed.

The two FFS partitions appear as the following two separate folders in the Windows CE file system:

- Platform: The Platform FFS partition contains Motorola-supplied programs and Dynamic Link Libraries (DLLs). This FFS is configured to include DLLs that control system operation. Since the MK4000 needs these drivers for basic operation, only experienced users should modify the content of this partition.
- Application: The Application FFS partition stores application programs needed to operate the MK4000.

### Working with FFS Partitions

Because the FFS partitions appear as folders under the Windows CE file system, you can read and write to them like any other folder. For example, an application program can write data to a file located in the Application folder just as it would to the Windows folder. However, the file in the Application folder is in non-volatile storage and is not lost on a cold boot (e.g., when power is removed for a long period of time).

You can use standard tools such as ActiveSync to copy files to and from the FFS partitions. They appear as the *Application* and *Platform* to the ActiveSync explorer. This is useful when installing applications on the MK4000. Applications stored in the Application folder are retained even after a cold boot.

There are two device drivers included in the Windows CE image to assist developers in configuring the MK4000 following a cold boot: RegMerge and CopyFiles.

#### RegMerge.dll

RegMerge.dll is a built-in driver that allows making registry edits to the Windows CE Registry. Regmerge.dll runs very early in the boot process and looks for registry files (.reg files) in certain Flash File System folders during a cold boot. It then merges the registry changes into the system registry located in RAM.

Since the registry is re-created on every cold boot from the default ROM image, the RegMerge driver is necessary to make registry modifications persistent over cold boots.

RegMerge looks in the root of two specific folders for .reg files in the following order:

\Platform  
\Application

Regmerge continues to look for .reg files in these folders until it checks all folders. This allows folders later in the list to override folders earlier in the list. This way, it is possible to override Registry changes made by the Platforms partitions folders. Take care when using Regmerge to make Registry changes. The DCP contains examples of .reg files.

✓ **NOTE** Regmerge only merges the .reg files on cold boots. A warm boot skips the merge process.



Typically, you would not modify the registry values for drivers loaded before RegMerge, although this may be necessary during software development. Since these early loading drivers read these keys before RegMerge can change them, you must cold boot the MK4000. The warm boot does not re-initialize the registry and the early loading driver reads the new registry values.

Do not use Regmerge to modify built-in driver registry values, or merge the same Registry value to two files in the same folder, as the results are not predictable.

## CopyFiles

Windows CE expects certain files to be in the Windows folder, residing in volatile storage. Windows CE maintains the System Registry in volatile storage. CopyFiles copies files from one folder to another on a cold boot. Files can be copied from a non-volatile partition (Application or Platform) to the Windows or other volatile partition during a cold boot. During a cold boot CopyFiles looks for files with a .CPY extension in the root of the Platform, then the Application FFS partitions. These files are text files containing the source and destination for the desired files to copy, separated by ">". The demo application partition included in the DCP contains the following example from the file application.cpy. Alternatively, obtain this from the Support Central web site at <http://www.motorola.com/enterprisemobility/support>.

Files are copied to the Windows folder from the Flash File System using copy files (\*.cpy) in the following order:

```
\Platform
  \Application
```

Example:

```
Application\ScanSamp2.exe>\Windows\ScanSamp2.exe
```

This line directs CopyFiles to copy the ScanSamp2.exe application from the \Application folder to the \Windows folder.

## Non-FFS Partitions

Non-FFS Partitions include additional software and data pre-loaded on the MK4000 that you can upgrade. Unlike FFS Partitions, these partitions are not visible when the operating system is running. They also contain system information. Non-FFS partitions include the following:

- Windows CE: The complete Windows CE operating system is stored on Flash devices. If necessary, you can download the entire OS image to the MK4000 using Motorola provided files. The TCM installation package includes the current OS partition on the MK4000. Obtain any upgrades from Motorola. This partition is mandatory for the MK4000.
  - Splash Screen: a bitmap smaller than 16 kb (and limited to 8 bits per pixel) appears as the MK4000 cold boots. To download a customized screen to display, see [Creating a Splash Screen on page 5-17](#).
- ✓ **NOTE** 8 bits per pixel only applies to splash screen images. Once Windows CE is running, the color density is 16 bits per pixel.
- Partition Table: Identifies where each partition is loaded in the MK4000.

## Downloading Partitions to the MK4000

Use TCM to specify a hex destination file for each partition and download each file to the MK4000. This download requires a program loader stored on the MK4000.





# Appendix A Technical Specifications

---

## Technical Specifications

For the latest technical specification information for the MK4000, visit: <http://www.motorola.com/MK4000>



# Appendix B Wireless Configuration

---

## Overview

Use the MK4000's Mobile Companion to configure the 11 Mbps wireless connection.

✓ **NOTE** Mobile Companion supports WPA Home, but not WPA Enterprise.

## Wireless Applications

Wireless Local Area Networks (WLANs) allow MK4000s to communicate wirelessly and send data to a host device in real time. Before using the MK4000 on a WLAN, the facility must be set up with the required hardware to run the wireless LAN and you must configure the device. Refer to the documentation provided with the access points (APs) for instructions on setting up the hardware.

To configure the MK4000, a set of wireless applications provide the tools to configure and test the wireless radio in the device. The **Wireless Application** menu on the task tray provides the following wireless applications:

- Find WLANs
- Manage Profiles
- Manage Certificates
- Manage PACs
- Options
- Wireless Status
- Wireless Diagnostics
- Log On/Off
- Enable/Disable Radio (Fusion 2.5 and above only).

Tap the **Signal Strength** icon to display the **Wireless Applications** menu.

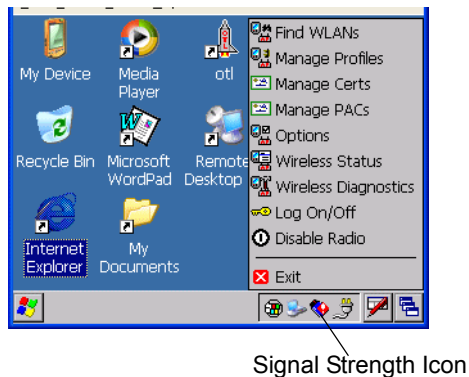







**Figure B-1** *Wireless Applications Menu*

## Signal Strength Icon

The **Signal Strength** icon in the task tray indicates the device's wireless signal strength as follows:

**Table B-1** *Wireless Applications Icons, Signal Strength Descriptions*

Icon	Status	Action
	Excellent signal strength	Wireless LAN network is ready to use.
	Very good signal strength	Wireless LAN network is ready to use.
	Good signal strength	Wireless LAN network is ready to use.
	Fair signal strength	Wireless LAN network is ready to use. Notify the network administrator that the signal strength is only "Fair".
	Poor signal strength	Wireless LAN network is ready to use. Performance may not be optimum. Notify the network administrator that the signal strength is "Poor".
	Out-of-network range (not associated)	No wireless LAN network connection. Notify the network administrator.
	No wireless LAN network card detected.	No wireless LAN network card detected or radio disabled. Notify the network administrator.
None	No wireless LAN network card detected or Wireless LAN disabled.	No wireless LAN network card detected or Wireless LAN disabled or radio disabled. Notify the network administrator.

## Turning the WLAN Radio On and Off

To turn the WLAN radio off tap the **Signal Strength** icon and select **Disable Radio**.

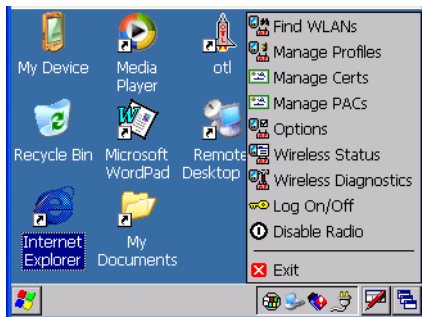
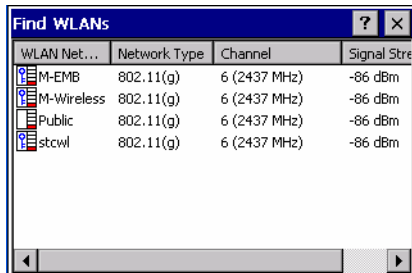

**Figure B-2** *Disable Radio*

To turn the WLAN radio on tap the **Signal Strength** icon and select **Enable Radio**.

## Find WLANs Application

Use the **Find WLANs** application to discover available networks in the vicinity of the user and MK4000. To open the **Find WLANs** application, tap the **Signal Strength** icon - **Find WLANs**. The **Find WLANs** window displays.



**Figure B-3** Find WLANs Window

- ✓ **NOTE** Find WLAN display is limited to 32 items (ESSIDs or MAC addresses). A combination of up to 32 ESSIDs/APs may be displayed.

Manually enter valid ESSIDs not displayed in the **Find WLANs** window. See [Figure B-4 on page B-6](#).

The **Find WLANs** list displays:



- WLAN Networks - Available wireless networks with icons that indicate signal strength and encryption type. The signal strength and encryption icons are described in [Table B-2](#) and [Table B-3](#).
- Network Type - Type of network.
- Channel - Channel on which the AP is transmitting.
- Signal Strength - The signal strength of the signal from the AP.

**Table B-2** Signal Strength Icon

Icon	Description
	Excellent signal
	Very good signal
	Good signal
	Fair signal
	Poor signal
	Out of range or no signal



**Table B-3** *Encryption Icon*

Icon	Description
	No encryption. WLAN is an infrastructure network.
	WLAN is an Ad-Hoc network.
	WLAN access is encrypted and requires a password.

Tap-and-hold on a WLAN network to open a pop-up menu which provides two options: **Connect** and **Refresh**. Select **Refresh** to refresh the WLAN list. Select **Connect** to create a wireless profile from that network. This starts the **Profile Editor Wizard** which allows you to set the values for the selected network. After editing the profile, the device automatically connects to this new profile.

## Profile Editor Wizard

Use the **Profile Editor Wizard** to create a new WLAN profile or edit an existing profile. If editing a profile, the fields reflect the current settings for that profile. If creating a new profile, default values appear in the fields.

Navigate through the wizard using the **Next** and **Back** buttons. Tap **X** to quit. On the confirmation dialog box, tap **No** to return to the wizard or tap **Yes** to quit and return to the **Manage Profiles** window. See [Manage Profiles Application on page B-30](#) for instructions on navigating the **Profile Editor Wizard**.

### Profile ID

In the **Profile ID** dialog box in the **Profile Editor Wizard**, enter the profile name and the ESSID.

**Figure B-4** Profile ID Dialog Box

**Table B-4** Profile ID Fields

Field	Description
Profile Name	The name and (WLAN) identifier of the network connection. Enter a user friendly name for the device profile used to connect to either an AP or another networked computer. Example: The Public LAN.
ESSID	The ESSID is the 802.11 extended service set identifier. The ESSID is 32-character (maximum) string identifying the WLAN, and must match the AP ESSID for the device to communicate with the AP.

✓ **NOTE** Two profiles with the same user friendly name are acceptable but not recommended.

Tap **Next**. The **Operating Mode** dialog box displays.

## Operating Mode

Use the **Operating Mode** dialog box to select the operating mode (Infrastructure or Ad-Hoc) and the country location.

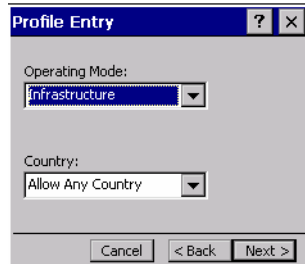

**Figure B-5** *Operating Mode Dialog Box*

**Table B-5** *Operating Mode Fields*

Field	Description
Operating Mode	Select <b>Infrastructure</b> to enable the device to transmit and receive data with an AP. Infrastructure is the default mode. Select <b>Ad Hoc</b> to enable the device to form its own local network where devices communicate peer-to-peer without APs using a shared ESSID.

**Table B-5** *Operating Mode Fields (Continued)*

Field	Description
Country	<p><b>Country</b> determines if the profile is valid for the country of operation. The profile country must match the country in the options page or it must match the acquired country if 802.11d is enabled.</p> <hr/> <p><b>Single Country Use:</b> If using the device in a single country, set every profile country to <b>Allow Any Country</b>. In the <b>Options &gt; Regulatory</b> dialog box (see <a href="#">Figure B-41 on page B-46</a>), select the specific country in which the device is used, and deselect the <b>Enable 802.11d</b> option. This common and efficient configuration eliminates the initialization overhead associated with acquiring a country via 802.11d.</p> <hr/> <p><b>Multiple Country Use:</b> If using the device in more than one country, select <b>Enable 802.11d</b> in the <b>Options &gt; Regulatory</b> dialog box (see <a href="#">Figure B-41 on page B-46</a>). This eliminates the need for reprogramming the country (in <b>Options &gt; Regulatory</b>) each time you enter a new country. However, this only works if the infrastructure (i.e., APs) supports 802.11d (older firmware versions on wireless infrastructures do not support 802.11d). When you select the <b>Enable 802.11d</b> option, the <b>Options &gt; Regulatory &gt; Country</b> setting is not used for infrastructure WLANs. 802.11d feature is only valid for Infrastructure WLANs. Ad-hoc WLANs use the country options and must match the profile.</p> <p>For a single profile to use in multiple countries, with infrastructure that supports 802.11d (including Motorola infrastructure), set the Profile Country to <b>Allow Any Country</b>. Under <b>Options &gt; Regulatory</b>, select <b>Enable 802.11d</b>. The <b>Options &gt; Regulatory &gt; Country</b> setting is not used.</p> <hr/> <p>For a single profile to use in multiple countries, but with infrastructure that does not support 802.11d, set the profile country to <b>Allow Any Country</b>, and de-select (uncheck) <b>Enable 802.11d</b>. In this case, always set the <b>Options &gt; Regulatory &gt; Country</b> setting to the country the device is currently in. You can use this efficient configuration option with any infrastructure. However, you must manually change the <b>Options &gt; Regulatory &gt; Country</b> setting when entering a new country.</p> <p>Note that using a single profile in multiple countries implies that there is a common ESSID to connect to in each country. This is less likely than having unique ESSIDs in each country, which requires unique profiles for each country.</p> <hr/> <p>For additional efficiency when using multiple profiles to use in multiple countries, set the country setting for each profile to a specific country. If the current country (found via 802.11d or set by <b>Options &gt; Regulatory &gt; Country</b> when 802.11d is disabled) does not match the country set in a given profile, that profile is disabled. This can speed profile roaming. For example, if you create and configure two profiles for Japan, and two more for USA, then when in Japan only the first two profiles are active, and when in USA only the last two are active. If you configure them all for <b>Allow Any Country</b>, all four are always active, making profile roaming less efficient.</p>

Tap **Next**. If you selected **Ad-Hoc** mode, the **Ad-Hoc Channel** dialog box displays. If you selected **Infrastructure** mode, the **Security Mode** dialog box displays. See [Authentication on page B-11](#) for instruction on setting up authentication.

## Ad-Hoc

Use the **Ad-Hoc Channel** dialog box to select the required information to create an Ad-Hoc profile. This dialog box does not appear if you selected **Infrastructure** mode.

1. Select a channel number from the **Channel** drop-down list.

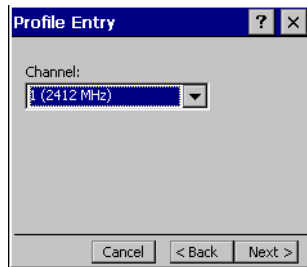

**Figure B-6** Ad-Hoc Channel Selection Dialog Box

- ✓ **NOTE** If in a country where DFS is implemented in band 5150-5250 MHz, you cannot use ad-hoc and must move and select a channel in the 2.4 GHz band.

Ad-hoc channels are specific to the country selected.

**Table B-6** Ad-Hoc Channels

Band	Channel	Frequency
2.4 GHz	1	2412 MHz
	2	2417 MHz
	3	2422 MHz
	4	2427 MHz
	5	2432 MHz
	6	2437 MHz
	7	2442 MHz
	8	2447 MHz
	9	2452 MHz
	10	2457 MHz
	11	2462 MHz
	12	2467 MHz
	13	2472 MHz
	14	2484 MHz

**Table B-6** *Ad-Hoc Channels*

Band	Channel	Frequency
5 GHz	36	5180 MHz
	40	5200 MHz
	44	5220 MHz
	48	5240 MHz

2. Tap **Next**. The **Encryption** dialog box displays. See [Encryption on page B-21](#) for encryption options.

## Security Mode

Use the Security Mode dialog box to configure the Security and Authentication methods. If you selected **Ad-Hoc** mode, this dialog box is not available and authentication is set to **None** by default.

**Figure B-7** *Security and Authentication Dialog Box*

Select the security mode from the **Security Mode** drop-down list. This selection affects the availability of other choices for Authentication Type and Encryption methods.

- LEGACY (Pre-WPA) - This mode allows you to configure protocols not available in the other Security Mode selections: Open authentication / encryption, Open authentication with WEP40 or WEP128, and 802.1X authentications that use WEP128 encryption.
- WPA-Personal - This mode allows you to configure a WPA-TKIP-PSK protocol.
- WPA2-Personal - This mode allows you to configure WPA2-PSK protocols with either the Advanced Encryption Standard (AES) or TKIP encryption method.
- WPA-Enterprise - This mode allows you to configure profiles with 802.1X Authentication that uses WPA and TKIP encryption method.
- WPA2-Enterprise - This mode allows you to configure profiles with 802.1X Authentication that uses WPA2 with AES encryption method.

**Table B-7** Security Modes

Security Mode	Authentication Types	Encryption Types	Pass-phrase/Hexkey Configuration
Legacy (Pre-WPA)	None, EAP-TLS, EAP-FAST, PEAP, LEAP, TTLS	Open, WEP-40 (40/24), WEP-104 (104/24), TKIP, AES	Enabled. User input required with pass-phrase/hex key configuration.
WPA - Personal	None	TKIP	Enabled. User input required with pass-phrase/hex key configuration.
WPA2 - Personal	None	AES	Enabled. User input required with pass-phrase/hex key configuration.
WPA - Enterprise	EAP-TLS, EAP-FAST, PEAP, LEAP, TTLS	TKIP	Disabled. No user input required for encryption key.
WPA2 - Enterprise	EAP-TLS, EAP-FAST, PEAP, LEAP, TTLS	AES	Disabled. No user input required for encryption key.

## Authentication

Select an available authentication type from the drop-down list. The options listed are based on the selected Security Mode as shown in [Table B-7](#).

The authentication types, other than **None**, all use IEEE 802.1x authentication to ensure that only valid users and sometimes servers can connect to the network. Each authentication type uses a different scheme using various combinations of tunnels, username/passwords, user certificates, server certificates, and Protected Access Credentials (PACs).

**Table B-8** Authentication Options

Authentication	Description
None	Default setting when authentication is not required on the network.
EAP-TLS	Select this option to enable EAP-TLS authentication. A user certificate is required; validating the server certificate is optional.
EAP-FAST	Select this option to enable EAP-FAST authentication. This type uses a PAC (Protected Access Credential) to establish a tunnel and then uses the selected tunnel type to verify credentials. PACs are handled behind the scenes, transparent to the user. Automatic PAC provisioning can, depending on the tunnel type, require a user certificate and the validation of a server certificate. Manual PAC provisioning is currently not supported.

**Table B-8** *Authentication Options (Continued)*

Authentication	Description
PEAP	Select this option to enable PEAP authentication. This type establishes a tunnel and, based on the tunnel type, uses a user certificate and/or a username/password. Validating the server certificate is optional.
LEAP	Select this option to enable LEAP authentication. This type does not establish a tunnel. It requires a username and password.
TTLS	Select this option to enable TTLS authentication. This type establishes a tunnel and, based on the tunnel type, uses a user certificate and/or a username/password. Validating the server certificate is optional.

Tap **Next**. Selecting **PEAP**, **TTLS**, or **EAP-FAST** displays the **Tunneled Authentication Type** dialog box. Selecting **None** displays the **Encryption** dialog box. Selecting **EAP-TLS** displays the **Installed User Certs** dialog box. Selecting **LEAP** displays the **User Name** dialog box.

## Tunneled Authentication

Use the **Tunneled Authentication** dialog box to select the tunneled authentication options. The content of the dialog differs depending on the **Authentication Type** chosen.

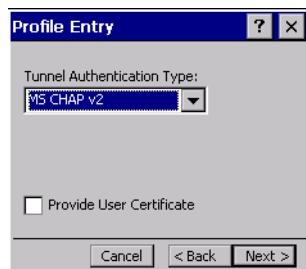
**Figure B-8** *Tunneled Authentication Dialog Box*

To select a tunneled authentication type:

1. Select a tunneled authentication type from the drop-down list. See [Table B-9](#) for the Tunnel authentication options for each authentication type.
2. Select the **User Certificate** check box if a certificate is required. If you selected the TLS tunnel type that requires a user certificate, the check box is already selected.
3. Tap **Next**. The **Installed User Certificates** dialog box appears.



**Table B-9** *Tunneled Authentication Options*

Tunneled Authentication	Authentication Type			Description
	PEAP	TTLS	EAP-FAST	
CHAP		X		Challenge Handshake Authentication Protocol (CHAP) is one of the two main authentication protocols used to verify the user name and password for PPP Internet connections. CHAP is more secure than PAP because it performs a three way handshake during the initial link establishment between the home and remote machines. It can also repeat the authentication anytime after the link is established.
EAP-GTC	X		X	EAP-GTC is used during phase 2 of the authentication process. This method uses a time-synchronized hardware or software token generator, often in conjunction with a user PIN, to create a one-time password.
MD5		X		Message Digest-5 (MD5) is an authentication algorithm developed by RSA. MD5 generates a 128-bit message digest using a 128-bit key, IPsec truncates the message digest to 96 bits.
MS CHAP		X		Microsoft Challenge Handshake Authentication Protocol (MS CHAP) is an implementation of the CHAP protocol that Microsoft created to authenticate remote Windows workstations. MS CHAP is identical to CHAP, except that MS CHAP is based on the encryption and hashing algorithms used by Windows networks, and the MS CHAP response to a challenge is in a format optimized for compatibility with Windows operating systems.

**Table B-9** *Tunneled Authentication Options (Continued)*

Tunneled Authentication	Authentication Type			Description
	PEAP	TTLS	EAP-FAST	
MS CHAP v2	X	X	X	Microsoft Challenge Handshake Authentication Protocol version 2 (MS CHAP v2) is a password-based, challenge-response, mutual authentication protocol that uses the industry-standard Message Digest 4 (MD4) and Data Encryption Standard (DES) algorithms to encrypt responses. The authenticating server challenges the access client and the access client challenges the authenticating server. If either challenge is not correctly answered, the connection is rejected. MS CHAP v2 was originally designed by Microsoft as a PPP authentication protocol to provide better protection for dial-up and virtual private network (VPN) connections. With Windows XP SP1, Windows XP SP2, Windows Server 2003, and Windows 2000 SP4, MS CHAP v2 is also an EAP type.
PAP		X		Password Authentication Protocol (PAP) has two variations: PAP and CHAP PAP. It verifies a user name and password for PPP Internet connections, but it is not as secure as CHAP, since it works only to establish the initial link. PAP is also more vulnerable to attack because it sends authentication packets throughout the network. Nevertheless, PAP is more commonly used than CHAP to log in to a remote host like an Internet service provider.
TLS	X		X	EAP TLS is used during phase 2 of the authentication process. This method uses a user certificate to authenticate.

## User Certificate Selection

If you checked the **User Certificate** check box on the **Tunneled Authentication** dialog box or if **TLS** is the selected authentication type, the **Installed User Certificates** dialog box displays. Select a certificate from the drop-down list of currently installed certificates before proceeding. The selected certificate's name appears in the drop-down list. If the required certificate is not in the list, install it.

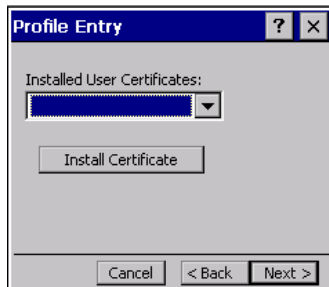

**Figure B-9** *Installed User Certificates Dialog Box*

## User Certificate Installation

There are two methods available to install a user certificate for authentication. The first is to obtain the user certificate from the Certificate Authority (CA). This requires connectivity with that CA. The second method is to install the user certificate from a file placed on the device.

To install a user certificate from the CA:

1. Tap **Install Certificate**. The **Import Certificate** dialog box appears.
2. Select **Import User Cert** from **Server** and tap **OK**. The **Install from Server** dialog box appears.
3. Enter the **User**, **Password**, and **Server** information in their respective text boxes.
4. Tap **Retrieve**. A Progress dialog indicates the status of the certificate retrieval or tap **Exit** to exit.

After the installation completes, the **Installed User Certs** dialog box displays and the certificate is available in the drop-down for selection.

✓ **NOTE** To successfully install a user certificate, the mobile computer must already be connected to a network from which the server is accessible.

To install a user certificate from a file:

1. Tap **Install Certificate**. The **Import Certificate** dialog box appears.
2. Choose **Import from File** and tap **OK**. The **Open** dialog box appears.
3. In the **Type** drop-down list, select **Personal Certs (\*.pfx)**.
4. Browse to the file and tap **OK**. The **Personal Certificate** dialog box appears.
5. Enter the password and select **OK**. The certificate(s) are imported.

✓ **NOTE** To install a user certificate from a file, the file must be of type "\*.pfx". Also, this file type requires you to supply a password in order to be read by Fusion.

## Server Certificate Selection

If you select the **Validate Server Certificate** check box, a server certificate is required. Select a certificate on the **Installed Server Certificates** dialog box. An hour glass may appear as the wizard populates the existing certificate list. If the required certificate is not listed, install it:

1. Tap the **Install Certificate** button.

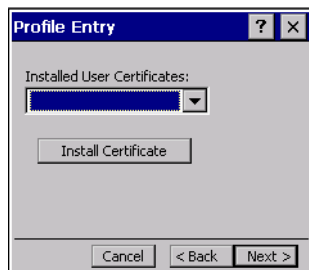

**Figure B-10** *Installed Server Certificates Dialog Box*

The **Import Certificate** dialog box appears. Choose **Import from File (.cer, .pfx)** and tap **OK**.

2. A dialog box appears that lists the certificate files found with the default extension. Browse to the file and tap **OK**.
3. A confirmation dialog verifies the installation. If the information in this dialog is correct, tap the **Yes** button. If the information in this dialog is not correct, tap the **No** button. The wizard returns to the **Installed Server Certs** dialog box. Select the newly-installed certificate from the drop down list.

## User Name

You can enter the user name and password when you create the profile, but is not required. If you do not enter the username and password in the profile, then when attempting to connect, you are prompted to supply them. The entered information (credentials) is saved (cached) for future reconnections.

Whether or not you enter the username and password into the profile affects how the profile is treated during a Profile Roaming operation. Profiles are excluded from consideration if they require user entry of credential information.

If the profile uses an authentication tunnel type of EAP-GTC and you selected **Token** (see [Password](#)), then you can control certain behavior by whether you enter a value in the **Enter User Name** field. If you enter a value in this field, when the Fusion software prompts you to enter credentials, the username field in the interactive credential dialog is initialized with the value you entered when creating the profile. If you enter a different value in the username field of the interactive credential dialog, it is cached and used to initialize the username field the next time the interactive credential dialog is shown for that profile.

If you do not enter a value in the **Enter User Name** field when you create an EAP-GTC token profile, the username field in the interactive credential dialog is initialized to blank. After you enter a username in the interactive credential dialog, it is cached as usual, but it is not used to initialize the username field the next time the interactive credential dialog is shown for that profile; the username field is still initialized to blank.

In summary, you can control whether the username field in the interactive credential dialog box is initialized, either with the last interactively-entered username for that profile or with the username entered into the profile, by whether any value is entered in the **Enter User Name** field during profile entry.

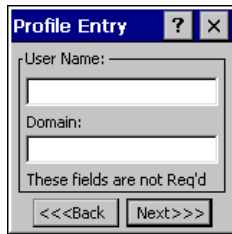

**Figure B-11** Username Dialog Box

## Password

Use the **Password** dialog box to enter a password. If EAP/TLS is the selected authentication type, the password dialog box does not appear. Note that if you entered a username but no password, Fusion assumes that no password is a valid password.

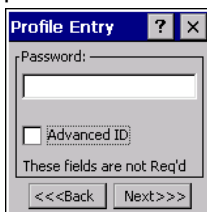

**Figure B-12** Password Dialog Box

1. Enter a password in the **Enter Password** field. If using the authentication tunnel type EAP-GTC, a **Password** dialog box appears, with two radio buttons to allow you to choose a token or static password.
  - Choose the **Token** radio button when using the profile in conjunction with a token generator (hardware or software). The system administrator supplies a token generator for use with EAP-GTC token profiles. A token generator generates a numeric value to enter in the password field at connect time, usually along with a PIN. Tokens usually expire within 60 seconds. The token generator is time-synchronized with a token server. When authenticating, the RADIUS server asks the token server to verify the token entered. The token server knows what value the token generator generates given the time of day and the username. Since tokens expire, EAP-GTC token profiles are treated differently. A prompt appears at the appropriate time to enter a token, even if you previously entered a token. Tokens are never cached in the credential cache (though the username entered when the token is entered is cached).
  - If you choose the **Static** radio button, the **Enter Password** field is enabled and you can enter a password if desired. A profile that uses an EAP-GTC tunnel type with a static password is handled in the same manner as other profiles that have credentials that don't expire.
2. Select the **Advanced ID** check box if advanced identification is desired.
3. Tap **Next**. The **Prompt for Login** at dialog box displays. See [Credential Cache Options](#).

## Advanced Identity

Use the **Advanced ID** dialog box to enter the 802.1X identity to supply to the authenticator. This value can be 63 characters long and is case sensitive. In TTLS and PEAP, entering an anonymous identity (rather than a true identity) plus any desired realm (e.g., anonymous@myrealm) is recommended. A user ID is required before proceeding.

✓ **NOTE** When authenticating with a Microsoft IAS server, do not use advanced identity.

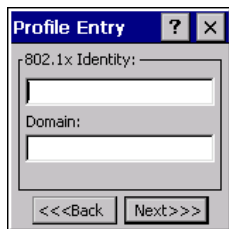

**Figure B-13** Advanced Identity Dialog Box

Tap **Next**. The **Encryption** dialog box displays.

## Credential Cache Options

If you selected any of the password-based authentication types, you can select different credential caching options. These options specify when the network credential prompts appear: at connection, on each resume, or at a specified time.

Entering the credentials directly into the profile permanently caches the credentials. In this case, the device does not require user login. If a profile does not contain credentials entered through the Profile Editor Wizard, you must enter credentials when prompted, either when connecting to the profile in the Manage Profiles window, or when logging onto the profile using the Log On/Off command.

Credential caching options only apply to a profile when you enter credentials through the login dialog box. This includes using the Log On/Off command to log on to a profile for which the credentials were directly entered into the profile (the username / password fields left blank).

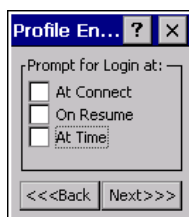

**Figure B-14** Prompt for Login at Dialog Box

If the device does not have the credentials, you are prompted to enter a username and password. If the device has the credentials (previous entered via a login dialog box), it uses these credentials unless the caching options require the device to prompt for new credentials. If you entered the credentials via the profile, the device does not prompt for new credentials (except for profiles where the credentials expire, such as EAP-GTC token profiles). [Table B-10](#) lists the caching options.

**Table B-10** *Cache Options*

Option	Description
At Connect	Select this option to prompt for credentials whenever the device tries to connect to a new profile. Deselect this to use the cached credentials to authenticate. If the credentials are not cached, you are prompted to enter credentials. This option only applies when logged in.
On Resume	Selecting this reauthenticates an authenticated user when a suspend/resume occurs. Once reauthenticated, the user is prompted for credentials. If the user does not enter the same credentials that were entered prior to the suspend/resume within three attempts, the user is disconnected from the network. This option only applies when logged in.
At Time	Select this option to perform a local verification on an authenticated user at a specified time. The time can be an absolute time or a relative time from the authentication, and should be in at least 5 minute intervals. Once the time has passed, the user is prompted for credentials. If the user does not enter the correct credentials within three attempts, the user is disconnected from the network. This option only applies when logged in.

Entering credentials applies these credentials to a particular profile. Logging out clears all cached credentials. Editing a profile clears all cached credentials for that profile. If you configure the APs to use the Fast Session Resume capability available with some authentication types (e.g., PEAP), do not check **At Connect** or **On Resume** if you want to avoid being prompted to re-enter credentials in circumstances in which Fast Session Resume would allow them not to be.

The following authentication types have credential caching:

- EAP-TLS
- PEAP
- LEAP
- TTLS
- EAP-FAST.

Some exceptions to the credential caching rules apply for profiles where the credentials expire, such as EAP-GTC token profiles. Since the token expires after a short period, you are prompted for credentials even when credentials were already entered and cached for that profile. The **At Connect** caching option has a slightly different function. If do not check the **At Connect** box, the Fusion software tries to authenticate without prompting for a new token. If Fast Session Reconnect is enabled on the RADIUS server and the device was previously connected and authenticated using the same profile, the device may be able to reconnect without the entire authentication process. In this case, new credentials are not required (even though the old ones have expired) and the Fusion software does not prompt for new credentials. If Fast Session Reconnect is not enabled on the RADIUS server or if you checked the **At Connect** checkbox, you are prompted to enter new credentials. Note also that the On Resume caching option must always check for profiles where the credentials expire, because the Fusion software does not support the use of Fast Session Reconnect across a suspend/resume cycle, so new credentials are always needed.

Selecting the **At Time** check box displays the **Time Cache Options** dialog box.

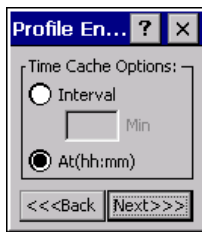

**Figure B-15** *Time Cache Options Dialog Box*

1. Tap the **Interval** radio button to check credentials at a set time interval.
2. Enter the value in minutes in the **Min** box.
3. Tap the **At (hh:mm)** radio button to check credentials at a set time.
4. Tap **Next**. The **At Time** dialog box appears.

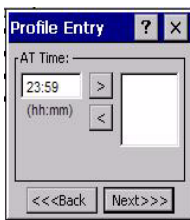

**Figure B-16** *At Time Dialog Box*

5. Enter the time using the 24 hour clock format in the **(hh:mm)** box.
6. Tap **>** to move the time to the right. Repeat for additional time periods.
7. Tap **Next**. The **Encryption** dialog box displays.



## Encryption

✓ **NOTE** The only available encryption methods in Ad-hoc are Open, WEP40, and WEP104.

Use the **Encryption** dialog box to select an encryption method. This contains fields to configure the encryption method and corresponding keys, if any. The drop-down list includes encryption methods available for the selected security mode and authentication type.

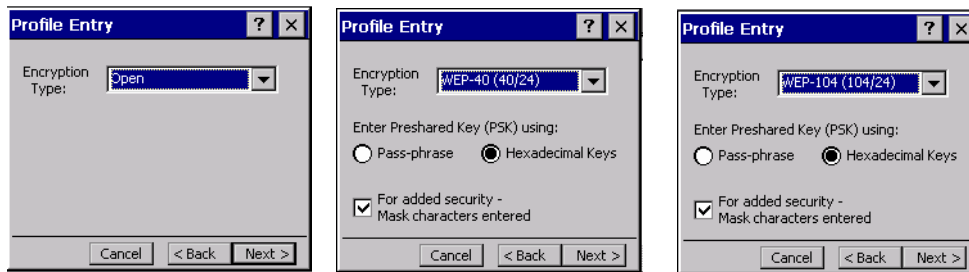

**Figure B-17** Encryption Dialog Box

Based on the encryption method and the authentication type, you may have to manually enter pre-shared encryption keys (or a passkey phrase). When you select any authentication type other than None, 802.1x authentication is used and the keys are automatically generated.

**Table B-11** Encryption Options

Encryption	Description
Open	Select <b>Open</b> (the default) when no data packet encryption is needed over the network. Selecting this option provides no security for data transmitting over the network.
WEP-40 (40/24)	Select <b>WEP-40 (40/24)</b> to use 64-bit key length WEP encryption (the other 24 bits are generated automatically). Other controls appear that allow you to enter keys. If you select the <b>Use Passkey</b> checkbox, you are asked to enter a passphrase between 4 and 32 characters long on the next page. Saving the profile converts the passphrase into a key and the passphrase is lost. Also, if using a passkey, only one key can be set.  If you do not select the <b>Use Passkey</b> checkbox, you can enter up to four hexadecimal keys on the next page. Select the key to enter in the <b>Key Index</b> drop-down menu. This also selects the key used for encryption. Note that Fusion sets default values for these keys, so while that entry is not required, the keys must match the AP.

**Table B-11** Encryption Options (Continued)

Encryption	Description
WEP-104 (104/24)	Select <b>WEP-104 (104/24)</b> to use a 128-bit key length WEP encryption. Other controls appear that allow you to enter keys. If you select the <b>Use Passkey</b> checkbox, you are asked to enter a passphrase between 4 and 32 characters long on the next page. Saving the profile converts the passphrase into a key and the passphrase is lost. Also, if using a passkey, only one key can be set.  If you do not select the <b>Use Passkey</b> checkbox, you can enter up to four hexadecimal keys on the next page. Select the key to enter in the <b>Key Index</b> drop-down menu. This also selects the key used for encryption. Note that Fusion sets default values for these keys, so while that entry is not required, the keys must match the AP.
TKIP	Select <b>TKIP</b> for the adapter to use the Temporal Key Integrity Protocol (TKIP) encryption method. This encryption method is available when the Security Mode is not set to Legacy. If the Security Mode is set to WPA personal, you are asked to enter a passphrase between 8 and 63 characters long on the next page.
AES (Fusion 2.5 only)	Select this option for the adapter to use the Advanced Encryption Standard (AES) method. This encryption method is available for many of the Security Modes. If the Security Mode selected is "personal", you are asked to enter a passphrase between 8 and 63 characters long on the next page.

**Table B-12** Encryption / Authentication Matrix

Authentication	Encryption					
	Legacy (Pre-WPA)		WPA Personal	WPA2 Personal	WPA Enterprise	WPA2 Enterprise
	Open	WEP	TKIP	AES	TKIP	AES
None	Yes	WEP-40 or WEP-104	Yes	Yes		
EAP-TLS		WEP-104			Yes	Yes
EAP-FAST		WEP-104			Yes	Yes
PEAP		WEP-104			Yes	Yes
LEAP		WEP-104			Yes	Yes
TTLS		WEP-104			Yes	Yes

If you selected either WEP-40 (40/24) or WEP-104 (104/24), the wizard displays the **Key Entry** dialog box unless you selected the **Use Passkey** check box in the **Encryption** dialog box (see [Figure B-17 on page B-21](#)). The **Key Entry** dialog box appears only if the authentication is set to **None**.

## Key Entry Page - Hexidecimal Keys

To enter the hexadecimal key information select the **Hexidecimal Keys** radio button in the **Encryption** dialog box. To enter a hexadecimal key with characters hidden:

1. Select the **For added security - Mask characters entered** check box.
2. Tap **Next**.

WEP-40 Keys Dialog Box

WEP-104 Keys Dialog Box

**Figure B-18** WEP-40 and WEP-104 Keys Dialog Boxes

3. For WEP only, in the **Edit Key** drop-down list, select the key to enter.
4. In the **Key** field, enter the key.
  - a. For WEP-40 enter 10 hexadecimal characters.
  - b. For WEP-104 enter 26 hexadecimal characters.
  - c. For TKIP enter 64 hexadecimal characters.
  - d. For AES enter 64 hexadecimal characters.
5. In the **Confirm Key** field, re-enter the key. When the keys match a message appears indicating this.
6. Repeat for each WEP key.
7. For WEP only, in the **Transmit Key** drop-down list, select the key to transmit.
8. Tap **Next**. The **IP Address Entry** dialog box displays.

To enter a hexadecimal key without characters hidden:

1. Tap **Next**.
2. For WEP only, in each **Key** field, enter the key.
  - a. For WEP-40 enter 10 hexadecimal characters.
  - b. For WEP-104 enter 26 hexadecimal characters.
  - c. For TKIP enter 64 hexadecimal characters.
  - d. For AES enter 64 hexadecimal characters.
3. For WEP only, in the **Transmit Key** drop-down list, select the key to transmit.
4. Tap **Next**. The **IP Address Entry** dialog box displays.

## Pass-phrase Dialog

When you select **None** as an authentication and **WEP** as an encryption, you can choose to enter a pass-phrase by checking the **Pass-phrase** radio button. You are prompted to enter the pass-phrase. For WEP, the **Pass-phrase** radio button is only available if the authentication is **None**.

When you select **None** as an authentication and **TKIP** as an encryption, you must enter a pass-phrase. You cannot enter a pass-phrase if the encryption is **TKIP** and the authentication is anything other than **None**.

When you select **None** as an authentication and **AES** as an encryption, you must enter a pass-phrase. You cannot enter a pass-phrase if the encryption is **AES** and the authentication is anything other than **None**.

To enter a pass-phrase with characters hidden:

1. Select the **For added security - Mask characters entered** check box.
2. Tap **Next**.
3. In the **Key** field, enter the key.
  - a. For WEP-40 enter between 4 and 32 characters.
  - b. For WEP-104 enter between 4 and 32 characters.
  - c. For TKIP enter between 8 and 63 characters.
  - d. For AES enter between 8 and 63 characters.
4. In the **Confirm Key** field, re-enter the key. When the keys match a message appears indicating this.
5. Tap **Next**. The **IP Address Entry** dialog box displays.

To enter a pass-phrase key without characters hidden:

1. Tap **Next**.
2. In the **Key** field, enter the key.
  - a. For WEP-40 enter between 4 and 32 characters.
  - b. For WEP-104 enter between 4 and 32 characters.
  - c. For TKIP enter between 8 and 63 characters.
  - d. For AES enter between 8 and 63 characters.
3. Tap **Next**. The **IP Address Entry** dialog box displays.

## IP Address Entry

Use the **IP Address Entry** dialog box to configure network address parameters: IP address, subnet mask, gateway, DNS, and WINS.

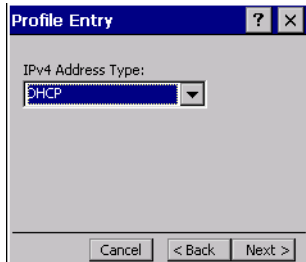

**Figure B-19** IP Address Entry Dialog Box

**Table B-13** IP Address Entry

Encryption	Description
DHCP	Select Dynamic Host Configuration Protocol ( <i>DHCP</i> ) from the <b>IP Address Entry</b> drop-down list to obtain a leased IP address and network configuration information from a remote server. DHCP is the default setting for the device profile. Ad-hoc mode does not support DHCP. Use only a Static IP address assignment.
Static	Select <b>Static</b> to manually assign the IP, subnet mask, default gateway, DNS, and WINS addresses the device profile uses.

Select either **DHCP** or **Static** from the drop-down list and tap **Next**. Selecting **Static IP** displays the **IP Address Entry** dialog box. Selecting **DHCP** displays the **Transmit Power** dialog box.

Use the **IP Address Entry** dialog box to enter the IP address and subnet information.

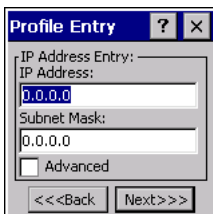
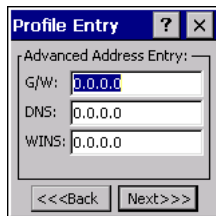

**Figure B-20** Static IP Address Entry Dialog Box

**Table B-14** *Static IP Address Entry Fields*

Field	Description
IP Address	The Internet is a collection of networks with users that communicate with each other. Each communication carries the address of the source and destination networks and the particular machine within the network associated with the user or host computer at each end. This address is called the IP address (Internet Protocol address). Each node on the IP network must be assigned a unique IP address that is made up of a network identifier and a host identifier. Enter the IP address as a dotted-decimal notation with the decimal value of each octet separated by a period, for example, 192.168.7.27.
Subnet Mask	Most TCP/IP networks use subnets to manage routed IP addresses. All IP addresses have a network part and a host part. The network part specifies a physical network. The host part specifies a host on that physical network. The subnet mask allows a network administrator to use some of the bits that are normally used to specify the host to instead specify physical sub-networks within an organization. This helps organize and simplify routing between physical networks.

Select the **Advanced** check box, then tap **NEXT** to display the **Advanced Address Entry** dialog box. Enter the Gateway, DNS, and WINS address. Tap **NEXT** without selecting the **Advanced** check box to display the **Transmit Power** dialog box.

**Figure B-21** *Advanced Address Entry Dialog Box*

The IP information entered in the profile is only used if you selected the **Enable IP Mgmt** check box in the **Options > System Options** dialog box ([System Options on page B-47](#)). If you didn't select this, the IP information in the profile is ignored and the IP information entered in the Microsoft interface applies.

**Table B-15** *IP Config Advanced Address Entry Fields*

Field	Description
G/W	The default gateway forwards IP packets to and from a remote destination.
DNS	The Domain Name System (DNS) is a distributed Internet directory service. DNS translates domain names and IP addresses, and controls Internet email delivery. Most Internet services require DNS to operate properly. If DNS is not configured, Web sites cannot be located and/or email delivery fails.
WINS	WINS is a Microsoft® Net BIOS name server. WINS eliminates the broadcasts needed to resolve computer names to IP addresses by providing a cache or database of translations.

Tap **Next**. The **Transmit Power** dialog box displays.

## Transmit Power

The **Transmit Power** drop-down list contains different options for Ad-Hoc and Infrastructure mode. Automatic (i.e., use the current AP settings) and Power Plus (use higher than the current AP settings) are available for **Infrastructure** mode.

Adjusting the radio transmission power level enables you to expand or confine the transmission coverage area. Reducing the radio transmission power level reduces potential interference to other wireless devices that might be operating nearby. Increasing the radio transmission power level increases the range at which other wireless devices can “hear” the radio’s signal.

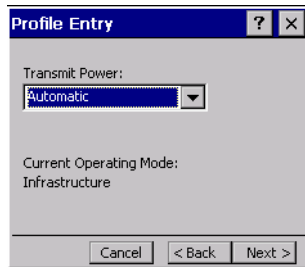

**Figure B-22** Transmit Power Dialog Box (Infrastructure Mode)

**Table B-16** Transmit Power Dialog Box (Infrastructure Mode)

Field	Description
Automatic	Select <b>Automatic</b> (the default) to use the AP power level.
Power Plus	Select <b>Power Plus</b> to set the device transmission power one level higher than the level set for the AP. The power level is set to conform to regulatory requirements.

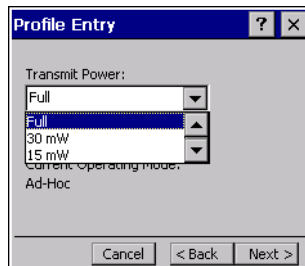

**Figure B-23** Transmit Power Dialog Box (Ad-Hoc Mode)

**Table B-17** *Power Transmit Options (Ad-Hoc Mode)*

Field	Description
Full	Select <b>Full</b> power for the highest transmission power level. Select <b>Full</b> power when operating in highly reflective environments and areas where other devices could be operating nearby, or when attempting to communicate with devices at the outer edge of a coverage area.
30 mW	Select <b>30 mW</b> to set the transmit power level to 30 mW. The radio transmits at the minimum power required.
15 mW	Select <b>15 mW</b> to set the transmit power level to 15 mW. The radio transmits at the minimum power required.
5 mW	Select <b>5 mW</b> to set the transmit power level to 5 mW. The radio transmits at the minimum power required.
1 mW	Select <b>1 mW</b> for the lowest transmission power level. Use this level when communicating with other devices in very close proximity, or in instances where you expect little or no radio interference from other devices.

Tap **Next** to display the **Battery Usage** dialog box.



## Battery Usage

Use the **Battery Usage** dialog box to select power consumption of the wireless LAN. There are three settings available: CAM, Fast Power Save, and MAX Power Save. Battery usage cannot be configured in Ad-Hoc profiles.

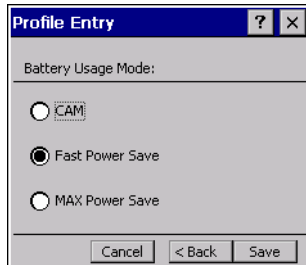

**Figure B-24** *Battery Usage Dialog Box*

✓ **NOTE** Power consumption is also related to the transmit power settings.

**Table B-18** *Battery Usage Options*

Field	Description
CAM	Continuous Aware Mode ( <b>CAM</b> ) provides the best network performance, but yields the shortest battery life.
Fast Power Save	<b>Fast Power Save</b> (the default) performs in the middle of CAM and MAX Power Save with respect to network performance and battery life.
MAX Power Save	<b>Max Power Save</b> yields the longest battery life while potentially reducing network performance. In networks with minimal latency, Max Power Save performs as well as Fast Power Save, but with increased battery conservation.

## Manage Profiles Application



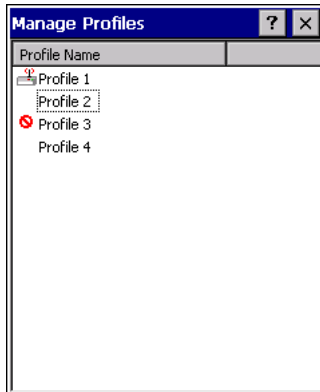



The **Manage Profiles** window provides a list of user-configured wireless profiles. Define up to 32 profiles at any one time. To open the **Manage Profiles** window, tap the **Signal Strength** icon > **Manage Profiles**.



**Figure B-25** *Manage Profiles Window*

Icons next to each profile identify the profile's current state.

**Table B-19** *Profile Icons*

Icon	Description
No Icon	Profile is not selected, but enabled.
	Profile is disabled.
	Profile is cancelled. A cancelled profile is disabled until a connect or login function is performed through the configuration editor.
	Profile is in use and describes an infrastructure profile not using encryption.
	Profile is in use and describes an infrastructure profile using encryption.
	Profile is in use and describes an ad-hoc profile not using encryption.
	Profile is in use and describes an ad-hoc profile using encryption.
	Profile is not valid in the device current operating regulatory domain.

The profiles are listed in priority order for use by the automatic roaming feature. Change the order by moving profiles up or down. To edit existing profiles, tap and hold one in the list and select an option from the menu to connect, edit, disable (enable), or delete the profile. Note that the **Disable** menu item changes to **Enable** if the profile is already disabled.

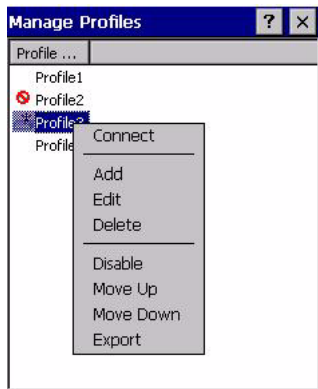

**Figure B-26** *Manage Profiles Context Menu*

## Changing Profiles

A completed profile is a set of configuration settings that you can use in different locations to connect to a wireless network. Create different profiles to have pre-defined operating parameters available for use in various network environments. When the **WLAN Profiles** window displays, existing profiles appear in the list.

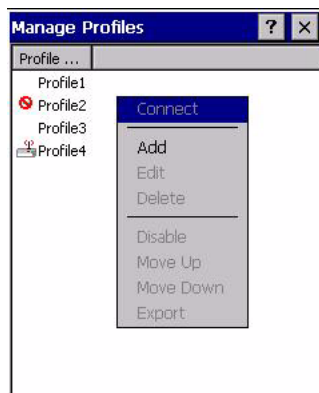

**Figure B-27** *Manage Profiles*

Tap and hold a profile and select **Connect** from the pop-up menu to set this as the active profile. Once selected, the device uses the authentication, encryption, ESSID, IP Config, and power consumption settings configured for that profile.

## Editing a Profile

Tap and hold a profile and select **Edit** from the pop-up menu to display the **Profile Wizard** where you can configure the profile settings. See [Profile Editor Wizard on page B-6](#) for instructions on editing a profile.

## Creating a New Profile

To create new profiles from the **Manage Profiles** window, tap-and-hold anywhere in this window.

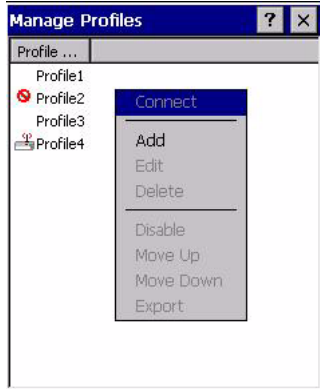

**Figure B-28** *Manage Profiles - Add*

Select **Add** to display the **Profile Wizard** wherein you can configure the profile settings, such as profile name, ESSID, security, network address information, and the power consumption level. See [Profile Editor Wizard on page B-6](#) for instructions on creating a profile.

## Deleting a Profile

To delete a profile from the list, tap and hold and select **Delete** from the pop-up menu. A confirmation dialog box appears.

## Ordering Profiles

Tap and hold a profile from the list and select **Move Up** or **Move Down** to order the profile. If the current profile association is lost, the device attempts to associate with the first profile in the list, then the next, until it achieves a new association.

✓ **NOTE** Profile Roaming must be enabled in the Options application. See [System Options on page B-47](#).

## Export a Profile

To export a profile to a registry file, tap and hold a profile from the list and select **Export** from the pop-up menu. The **Save As** dialog box displays with the **Application** folder and a default name of `WCS_PROFILE{profile GUID}.reg` (Globally Unique Identifier).

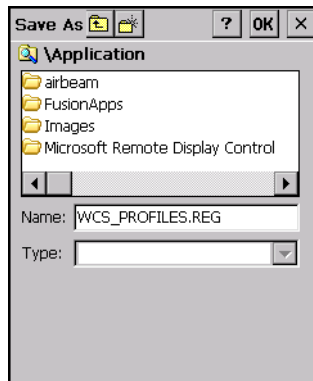

**Figure B-29** Save As Dialog Box

If required, change the name in the **Name** field and tap **Save**. A confirmation dialog box appears after the export completes.

---

## Manage Certificates

You can view and manage security certificates in the various certificate stores. Tap the **Signal Strength** icon > **Manage Certs**. The **Certificate Manager** window displays.

Various certificate types display. Select the **Certificate Type** drop-down box to filter the certificate list to display **All**, only **Root/Server**, or only **User/Client** certificates.

The **Certificate Manager** window contains command buttons at the bottom of the window. A button might be disabled (gray) if the operation cannot be performed based on any selected object.

To hide the command buttons to allow more space for displaying certificates, tap-and-hold and/or double-tap in the list area. In the pop-up menu, select **Hide Buttons**. To display the buttons, select **View Buttons**.

You can also use the pop-up menu to select the **Properties**, **Import**, and **Delete** commands.

## Certificate Properties

To display the properties of a certificate, select a certificate in the list and tap the **Properties** button. Select a property in the upper list to display the detailed information in the **Expanded Value** section.

Tap **ok**, **Escape**, or **X** to exit (depending on the device).

## Import a Certificate

Import a certificate from a file or from a server:

- .CER file - DER encrypted Root/Server certificates.
- .PFX file - Personal inFormation eXchange formatted file containing one or more Root/Server and/or User/Client Certificates. These files are usually protected by a password you must enter. If there is no password, enter nothing and select the **OK** button.
- Server - You can request User/Client certificates directly from a Certificate Authority (CA) on the network. You must provide a User name, Password (optional), and the Server (an IP address) to obtain a certificate for the User from the CA.

To import from a file:

1. Tap the **Import** button or select from the context menu. The **Import Certificate** dialog box displays.
2. Select the **Import from File (.cer, .pfx)** radio button to import a certificate file.
3. Select the file to import from the **Open** window.

To import from a server:

1. Tap the **Import** button or select from the context menu. The **Import Certificate** dialog box displays.
2. Select the **Import User Cert from Server** radio button to import a certificate from a server. The **Install From Server** window displays.
3. Enter the user, password, and server information in the respective text boxes.
4. Tap the **Retrieve** button to import the certificate.

## Delete a Certificate

To delete a certificates:

1. Select the certificate to delete.
2. Tap the **Delete** button or select **Delete** from the pop-up menu.

---

## Manage PACs

You can view and manage Protected Access Credentials (PACs) used by Cisco's EAP-FAST authentication protocol. PACs are uniquely identified by referencing a PAC Authority Identifier (A-ID) (the server that issued the PAC) and by the individual user identifier (I-ID). The PACs display sorted by A-ID (default) or by I-ID in a tree display.

Tap the **Signal Strength** icon > **Manage PACs**. The **PAC Manager** window displays.

To hide the buttons on the **PAC Manager** window to allow more space for displaying certificates, tap-and-hold or double-tap in the list area and select **Hide Buttons**. A button is disabled (gray) if the operation cannot be performed based on any selected object.

To display the buttons, select **View Buttons** from the pop-up menu.

You can also use the pop-up menu to select the **Properties** and **Delete** commands, or to sort by A-ID or I-ID.

### PAC Properties

To display the properties of a PAC, select an item in a sub-tree, and select the **Properties** button or pop-up menu. Select an entry in the upper list of the window to display the details of that property in the lower list.

To return to the main page, tap **Ok**, **Escape**, or **X**.

### Delete PAC

To delete a single PAC, tap a leaf item (right-most tree item) to select the PAC, then select the **Delete** button or **Delete** on the pop-up menu. A confirmation dialog box appears.

To delete a group of PACs with the same A-ID or I-ID, sort the PACs by ID type, then tap on the parent item (left-most tree item) to select the group. Select the **Delete** button or **Delete** on the pop-up menu. A confirmation dialog box appears.

---

## Wireless Status Application

To open the **Wireless Status** window, tap the **Signal Strength** icon > **Wireless Status**. The **Wireless Status** window displays information about the wireless connection.



**Figure B-30** *Wireless Status Window*

The *Wireless Status* window contains the following options. Tap the option to display the option window.

- Signal Strength - provides information about the connection status of the current wireless profile.
- Current Profile - displays basic information about the current profile and connection settings.
- IPv4 Status - displays the current IP address, subnet, and other IP related information assigned to the device.
- Wireless Log - displays a log of important recent activity, such as authentication, association, and DHCP renewal completion, in time order.
- Versions - displays software, firmware, and hardware version numbers.
- Quit - exits the **Wireless Status** window.

Option windows contain a back button  to return to the main **Wireless Status** window.



## Signal Strength Window

The **Signal Strength** window provides information about the connection status of the current wireless profile including signal quality, missed beacons, and transmit retry statistics. The BSSID address (shown as **AP MAC Address**) displays the AP currently associated with the connection. In Ad-Hoc mode, the AP MAC Address shows the BSSID of the Ad-Hoc network. Information in this window updates every 2 seconds.

To open the **Signal Status** window, tap **Signal Strength** in the **Wireless Status** window.

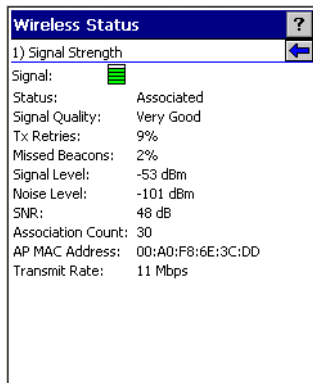

**Figure B-31** Signal Strength Window

After viewing the **Signal Strength** window, tap the back button to return to the **Wireless Status** window.

**Table B-20** Signal Strength Status

Field	Description
Signal	<p>Displays the Relative Signal Strength Indicator (RSSI) of the signal transmitted between the AP and device. As long as the Signal Quality icon is green the AP association is not jeopardized. If the icon is red (poor signal), an association with a different AP could be warranted to improve the signal. The signal strength icon changes depending on the signal strength.</p>  <ul style="list-style-type: none"> <li>Excellent Signal</li> <li>Very Good Signal</li> <li>Good Signal</li> <li>Fair Signal</li> <li>Poor Signal</li> <li>Out of Range (no signal)</li> </ul> <p>The radio card is off or there is a problem communicating with the radio card.</p>
Status	Indicates if the device is associated with the AP.
Signal Quality	Displays a text format of the Signal icon.
Tx Retries	Displays a percentage of the number of data packets the device retransmits. The fewer transmit retries, the more efficient the wireless network is.
Missed Beacons	Displays a percentage of the amount of beacons the device missed. The fewer missed beacons, the more efficient the wireless network is. Beacons are uniform system packets broadcast by the AP to keep the network synchronized.
Signal Level	The AP signal level in decibels per milliwatt (dBm).

**Table B-20** *Signal Strength Status (Continued)*

Field	Description
Noise Level	The background interference (noise) level in decibels per milliwatt (dBm).
SNR	The access point/device Signal to Noise Ratio (SNR) of signal strength to noise (interference) in decibels per milliwatt (dBm).
Association Count	Displays the number of times the device has roamed from one AP to another.
AP MAC Address	Displays the MAC address of the AP to which the device is connected.
Transmit Rate	Displays the current rate of the data transmission.

## Current Profile Window

The **Current Profile** window displays basic information about the current profile and connection settings. This window updates every two seconds.

To open the **Current Profile** window, tap **Current Profile** in the **Wireless Status** window.

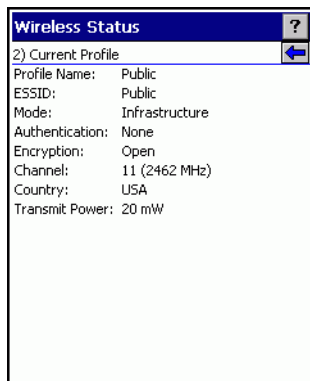
**Figure B-32** *Current Profile Window***Table B-21** *Current Profile Window*

Field	Description
Profile Name	Displays the current profile name the device uses to communicate with the AP.
ESSID	Displays the current profile's ESSID name.
Mode	Displays the current profile's mode, either Infrastructure or Ad-Hoc.
Authentication	Displays the current profile's authentication type.
Encryption	Displays the current profile's encryption type.
Channel	Displays the current profile's channel setting.
Country	Displays the current profile's country setting.
Transmit Power	Displays the radio transmission power level.

## IPv4 Status Window

The **IPv4 Status** window displays the current IP address, subnet, and other IP related information assigned to the device. It also allows renewing the address if the profile is using DHCP to obtain the IP information. Tap **Renew** to initiate the IP address renewal process. The **IPv4 Status** window updates automatically when the IP address changes.

To open the **IPv4 Status** window, tap **IPv4 Status** in the **Wireless Status** window.

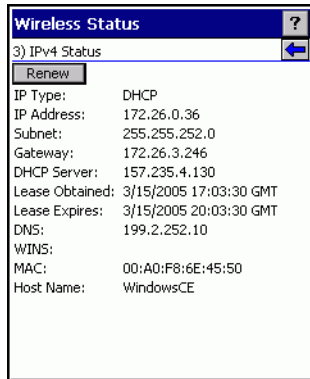

**Figure B-33** IPv4 Status Window

**Table B-22** IPv4 Status Fields

Field	Description
IP Type	Displays the IP address assignment method used for the current profile: <b>DHCP</b> or <b>Static</b> . If the <b>IP Type</b> is <b>DHCP</b> , the IP address and other information shown is obtained from the DHCP server. The DHCP server address and the lease information also appears. If the <b>IP Type</b> is <b>Static</b> , the window displays the IP address and other information entered in the profile.
IP Address	Displays the device's IP address. The Internet is a collection of networks with users that communicate with each other. Each communication carries the address of the source and destination networks and the particular machine within the network associated with the user or host computer at each end. This address is called the IP address. Each node on the IP network must be assigned a unique IP address that is made up of a network identifier and a host identifier. The IP address as a dotted-decimal notation with the decimal value of each octet separated by a period, for example, 192.168.7.27.
Subnet	Displays the device's subnet address. Most TCP/IP networks use subnets to manage routed IP addresses. All IP addresses have a network part that specifies a physical network, and a host part that specifies a host on that physical network. The subnet mask allows a network administrator to use some of the bits typically used to specify the host, to instead specify physical sub-networks within an organization. This helps organize and simplify routing between physical networks.
Gateway	Displays the gateway address. A gateway forwards IP packets to and from a remote destination.
DCHP Server	Displays the IP addresses of the DHCP server.
Lease Obtained	Displays the date and time that the IP address was obtained.

**Table B-22** IPv4 Status Fields (Continued)

Field	Description
Lease Expires	Displays the date and time that the IP address expires.
DNS	Displays the IP address of the DNS server.
WINS	WINS is a Microsoft Net BIOS name server. WINS eliminates the broadcasts needed to resolve computer names to IP addresses by providing a cache or database of translations.
MAC	An IEEE 48-bit address is assigned to the device at the factory to uniquely identify the adapter at the physical layer.
Host Name	Displays the name of the device.

## Wireless Log Window

The **Wireless Log** window displays a log of recent activity, such as authentication, association, and DHCP renewal completion, in time order. Save the log to a file or clear the log (within this instance of the application only). The auto-scroll feature automatically scrolls down when new items are added to the log.

To open the **Wireless Log** window, tap **Wireless Log** in the **Wireless Status** window. The **Wireless Log** window displays.

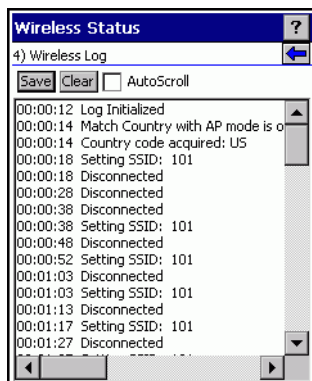
**Figure B-34** Wireless Log Window

### Saving a Log

To save a Wireless Log:

1. Tap the **Save** button. The **Save As** dialog box displays.
2. Navigate to the desired folder.
3. In the **Name** field, enter a file name and then tap **OK**. The Wireless Log is saved as a text file in the selected folder.

### Clearing the Log

To clear the log, tap **Clear**.

## Versions Window

The **Versions** window displays software, firmware, and hardware version numbers.

To open the **Versions** window, tap **Versions** in the **Wireless Status** window.

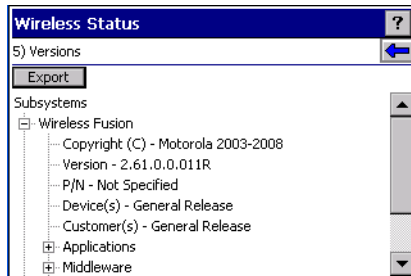

**Figure B-35** Versions Window

The window displays software version numbers as well as application and middleware version information.

---

## Wireless Diagnostics Application

The **Wireless Diagnostics** application window provides links to perform ICMP Ping, Trace Routing, and Known APs.

To open the **Wireless Diagnostics** window, tap the **Signal Strength** icon > **Wireless Diagnostics**.

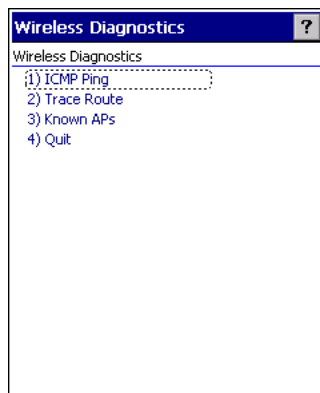

**Figure B-36** Wireless Diagnostics Window

The **Wireless Diagnostics** window contains the following options. Tap the option to display the option window.

- ICMP Ping - tests the wireless network connection.
- Trace Route - tests a connection at the network layer between the device and any place on the network.
- Known APs - displays the APs in range using the same ESSID as the device.
- Quit - Exits the **Wireless Diagnostics** window.

Option windows contain a back button  to return to the **Wireless Diagnostics** window.

## ICMP Ping Window

The **ICMP Ping** window allows testing a connection at the network layer (part of the IP protocol) between the device and any other device on the network. Ping tests only stop when you tap the **Stop Test** button, close the **Wireless Diagnostics** application, or if the device switches between infrastructure and ad-hoc modes.

To open the **ICMP Ping** window, tap the **ICMP Ping** in the **Wireless Diagnostics** window.

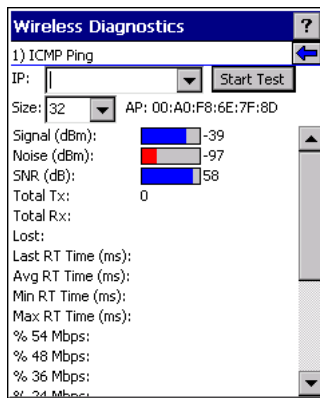

**Figure B-37** ICMP Ping Window

To perform an ICMP ping:

1. In the **IP** field, enter an IP address or select an IP address from the drop-down list.
2. From the **Size** drop-down list, select a size value.
3. Tap **Start Test**. The ICMP Ping test starts. Information of the ping test displays in the appropriate fields.

The following statistics appear on the page:

- **Signal** - The current signal strength, measured in dBm, appears as both a numeric value and as a histogram.
- **Noise** - The current noise level, measured in dBm, appears as both a numeric value and as a histogram.
- **SNR** - The current signal to noise ratio, measured in dBm, appears as both a numeric value and as a histogram.
- **Total Tx** - The total number of pings sent appears numerically.
- **Total Rx** - The total number of valid ping responses received appears numerically.
- **Lost** - The total number of pings lost appears numerically.
- **RT Times** - Four round trip times: Last, Average, Minimum, and Maximum appear in milliseconds.
- **% Rates** - For each of the 12 data rates, the number of times that rate was used to transmit the ping appears as a percentage.

## Graphs

Double-tap a statistic listed above to display a real time graph of that statistic.

## Trace Route Window

**Trace Route** traces a packet from a computer to a host, showing how many hops the packet requires to reach the host and how long each hop takes. The **Trace Route** utility identifies where the longest delays occur.

The **Trace Route** window allows testing a connection at the network layer (part of the IP protocol) between the device and any other device on the network.

To open the **Trace Route** window, tap **Trace Route** in the **Wireless Diagnostics** window.

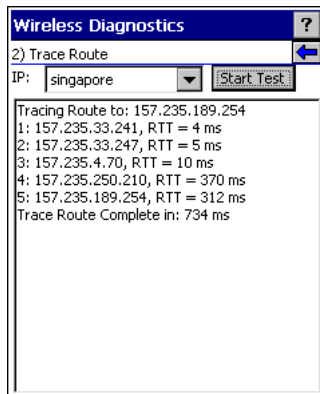
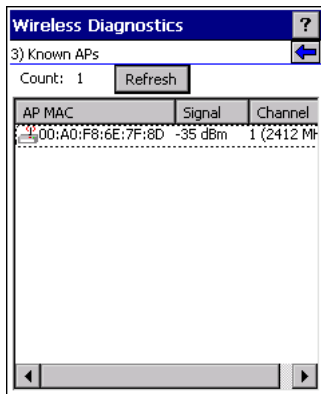

**Figure B-38** Trace Route Window

In the IP combo box, enter an IP address or choose one from the drop-down list, or enter a DNS Name, and tap **Start Test**. When starting a test, the trace route attempts to find all routers between the device and the destination. The Round Trip Time (RTT) between the device and each router appears, along with the total test time. The total test time may be longer than all RTTs added together because it does not only include time on the network.

## Known APs Window

The **Known APs** window displays the APs in range using the same ESSID as the device. This window is only available in **Infrastructure** mode. To open the **Known APs** window, tap **Known APs** in the **Wireless Diagnostics** window.



**Figure B-39** Known APs Window

See [Table B-23](#) for the definitions of the icons next to the AP.

**Table B-23** Current Profile Window

Icon	Description
	The AP is the associated access point, and is set to mandatory.
	The AP is the associated access point, but is not set to mandatory.
	The device is not associated to this AP, but the AP is set as mandatory.
	The device is not associated to this AP, and AP is not set as mandatory.

Tap and hold on an AP to display a pop-up menu with the following options: **Set Mandatory** and **Set Roaming**.

Select **Set Mandatory** to prohibit the device from associating with a different AP. The letter **M** displays on top of the icon. The device connects to the selected AP and never roams until:

- You select **Set Roaming**.
- You select **Set Mandatory** on a different AP.
- You manually connect to a profile from the **Manage Profiles** page.
- The device roams to a new profile.
- The device resumes after being suspended.
- The device resets (warm or cold).

Select **Set Roaming** to allow the device to roam to any AP with a better signal. These settings are temporary and never saved to the registry.

Tap **Refresh** to update the list of the APs with the same ESSID.



## Options

Use the wireless **Option** dialog box to select one of the following operation options from the drop-down list:

- Operating Mode (Op Mode) Filtering
- Regulatory
- Band Selection
- System Options
- Auto PAC Settings
- Change Password
- Export.

### Operating Mode Filtering

The **Operating Mode Filtering** options cause the Find WLANs application to filter the available networks found.

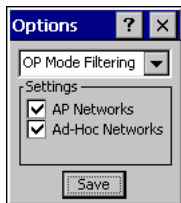

**Figure B-40** OP Mode Filtering Dialog Box

The **AP Networks** and **Ad-Hoc Networks** check boxes are selected by default.

**Table B-24** OP Mode Filtering Options

Field	Description
AP Networks	Select the <b>AP Networks</b> check box to display available AP networks and their signal strength within the <b>Available WLAN Networks</b> (see <a href="#">Find WLANs Application on page B-4</a> ). These are the APs available to the device for association. If this option was previously disabled, refresh the <b>Available WLAN Networks</b> window to display the AP networks available to the device.
AD-Hoc Networks	Select the <b>Ad-Hoc Networks</b> check box to display available peer (adapter) networks and their signal strength within the <b>Available WLAN Networks</b> . These are peer networks available to the device for association. If this option was previously disabled, refresh the <b>Available WLAN Networks</b> window to display the Ad Hoc networks available to the device.

Tap **Save** to save the settings or tap **X** to discard any changes.

## Regulatory Options

Use the **Regulatory** settings to configure the country the device is in. Due to regulatory requirements (within a country) a device is only allowed to use certain channels.



**Figure B-41** Regulatory Options Dialog Box

**Table B-25** Regulatory Options

Field	Description
Settings	Select the country from the drop-down list. If you did not select the <b>Enable 802.11d</b> check box, the profile country must match this setting to connect to that profile.
Enable 802.11d	If you select the <b>Enable 802.11d</b> check box, the WLAN adapter follows the 802.11d standard. It passively scans until it receives valid country information from an AP. It limits transmit power settings based on maximums received from the AP. Profiles using Infrastructure mode can only connect if the country selected in the profile matches the AP country setting, or if the profile country setting is <b>Allow Any Country</b> . Profiles which use Ad-hoc mode are not 802.11d compliant.

## Band Selection

The **Band Selection** settings identify the frequency bands to scan when finding WLANs. These values refer to the 802.11 standard networks.



- ✓ **NOTE** Select one band for faster access when scanning for WLANs.  
Not all mobile devices support both 2.4 GHz and 5 GHz bands.

**Figure B-42** Band Selection Dialog Box

**Table B-26** Band Selection Options

Field	Description
2.4GHz Band	The <b>Find WLANs</b> application list includes all networks found in the 2.4 GHz band (802.11b and 802.11g).
5GHz Band	The <b>Find WLANs</b> application list includes all networks found in the 5 GHz band (802.11a).

Tap **Save** to save the settings or tap **X** to discard any changes.

## System Options

Use **System Options** to set miscellaneous system setting.

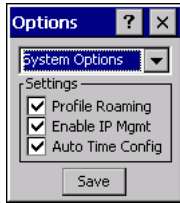

**Figure B-43** System Options Dialog Box

**Table B-27** System Options

Field	Description
Profile Roaming	Configures the device to roam to the next available WLAN profile when it moves out of range of the current WLAN profile.
Enable IP Mgmt	Enables the Wireless Companion Services to handle IP address management. The Wireless Companion Service configures the IP based on what is configured in the network profile. Deselect this to manually configure the IP in the standard Windows IP window. Enabled by default.
Auto Time Config	Enables automatic update of the system time. Network association updates the device time based on the time set in the AP. This proprietary feature is only supported with Motorola infrastructure. Enabled by default.

## Auto PAC Settings

Use the Auto PAC Settings to configure whether to allow automatic PAC provisioning and automatic PAC refreshing when using the EAP-FAST authentication protocol.

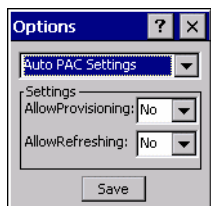

**Figure B-44** Auto PAC Settings Dialog Box

**Table B-28** Auto PAC Settings

Field	Description
Allow Provisioning	Select <b>Yes</b> from the drop-down list to allow automatically provisioning the device with a PAC when using the EAP-FAST authentication protocol. Select <b>No</b> to disallow automatic PAC provisioning.
Allow Refreshing	Select <b>Yes</b> from the drop-down list to allow automatically refreshing an existing PAC on the device when using the EAP-FAST authentication protocol. Select <b>No</b> to disallow automatic PAC refreshing.

If the master key expires, you must manually delete the PAC on the device generated with this expired key and provision a new PA, even if **Allow Refreshing** is enabled.

## Change Password

Use **Change Password** to require a password before creating or editing a profile or changing the **Options**. This allows pre-configuring profiles and prevents users from changing the network settings. The user can use this feature to protect settings from a guest user. By default, the password is not set.



**Figure B-45** *Change Password Window*

Enter the current password in the **Current** text box. If there is no current password, the **Current** text box does not appear. Enter the new password in the **New** and **Confirm** text boxes. Tap **Save**.

To change an existing password, enter the current password in the **Current:** text box and enter the new password in the **New:** and **Confirm:** text boxes. Tap **Save**.

To delete the password, enter the current password in the **Current:** text box and leave the **New:** and **Confirm:** text boxes empty. Tap **Save**.

✓ **NOTE** Passwords are case sensitive and can not exceed 63 characters.

## Export

Use **Export** to export all profiles to a registry file, and to export the options to a registry file.

- ✓ **NOTE** For Windows CE 5.0 devices, exporting options enables settings to persist after cold boot. See [Cold Boot Persistence on page B-50](#) for more information.



**Figure B-46** Options - Export Dialog Box

To export options:

1. Tap **Export Options**. The **Save As** dialog box displays.

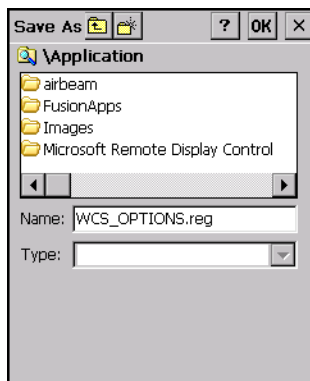
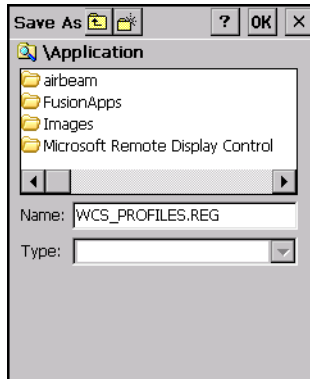

**Figure B-47** Export Options Save As Dialog Box

2. Enter a filename in the **Name:** field. The default filename is *WCS\_OPTIONS.REG*.
3. Select the desired folder.
4. Tap **Save**.

To export all profiles:

1. Tap **Export All Profiles**. The **Save As** dialog box displays.



**Figure B-48** *Export All Profiles Save As Dialog Box*

2. Enter a filename in the **Name:** field. The default filename is *WCS\_PROFILES.REG*.
3. In the **Folder:** drop-down list, select the desired folder.
4. Tap **Save**.

Selecting **Export All Profiles** saves the current profile. This information is used to determine which profile to connect with after a warm boot or cold boot.

---

## Cold Boot Persistence

Export options and profiles to provide cold boot persistence. Save the exported registry files in the **Application** folder to use them on a cold boot and restore previous profile and option settings.

To save server certificates for persistence, save the certificate files in the folder **Application\RootCerts** to install the certificates automatically on a cold boot.

User certificates that you install into the Microsoft Certificate Store, either through the Profile Editor Wizard or through the Fusion Certificate Manager application, are automatically saved in a special format to files in the **Application\UserCerts** folder. On a cold boot, the user certificates are automatically restored.

## Registry Settings

Use a registry key to modify some of the parameters. The registry path is:

HKLM\SOFTWARE\Symbol Technologies, Inc.\Configuration Editor

**Table B-29** Registry Parameter Settings

Key	Type	Default	Description												
CertificateDirectory	REG_SZ	\\Application	The default directory to find certificates.												
EncryptionMask	REG_DWORD	0x0000001F	<p>Defines the supported encryption types. This is a bitwise mask with each bit corresponding to an encryption type.</p> <p>1 = Type is supported 0 = Type is not supported</p> <table> <thead> <tr> <th>Bit Number</th> <th>Encryption Type</th> </tr> </thead> <tbody> <tr> <td>0</td> <td>None</td> </tr> <tr> <td>1</td> <td>40-Bit WEP</td> </tr> <tr> <td>2</td> <td>128-Bit WEP</td> </tr> <tr> <td>3</td> <td>TKIP</td> </tr> <tr> <td>4</td> <td>AES (Fusion 2.5 and above only)</td> </tr> </tbody> </table>	Bit Number	Encryption Type	0	None	1	40-Bit WEP	2	128-Bit WEP	3	TKIP	4	AES (Fusion 2.5 and above only)
Bit Number	Encryption Type														
0	None														
1	40-Bit WEP														
2	128-Bit WEP														
3	TKIP														
4	AES (Fusion 2.5 and above only)														

## Log On/Off Application

When you launch the **Log On/Off** application, the device may be in one of two states: either you are logged onto the device by already entering credentials through the login box, or you are not logged on. Each state has a separate set of use cases and a different look to the dialog box.

### User Already Logged In

If already logged into the device, you can launch the login dialog box for the following reasons:

- Connect to a different profile.
- Connect to and re-enable a cancelled profile. To do this:
  - Launch the **Log On/Off** dialog.
  - Select the cancelled profile from the profile drop-down list.
  - Login to the profile.

✓ **NOTE** Re-enable cancelled profiles using the **Manage Profiles** window to connect to the cancelled profile.

- Log off the device to prevent another user from accessing the current user's network privileges.
- Switch device users to quickly log off the device and allow another user to log into the device.

## No User Logged In

If no user is logged into the device, launch the login dialog box and log in to access user profiles. The **Login** dialog box varies if it is:

- Launched by the wireless application, because the service is connecting to a new profile that needs credentials.
- Launched by the wireless application, because the service is trying to verify the credentials due to credential caching rules.
- Launched by a user, when a user is logged in.
- Launched by a user, when no user is logged in.

**Table B-30** *Log On/Off Options*

Field	Description
Wireless Profile	When launching the login application, this field has available all the wireless profiles that require credentials. This includes profiles that use EAP-TLS, PEAP, LEAP, EAP-TTLS, or EAP-FAST.
Profile Status Icon	This icon (next to the profile name) indicates one of the following states: The selected profile is cancelled. The selected profile is enabled but is not the current profile. The profile is the current profile (always the case when the Wireless Application is launched).
Username, Password, and Domain Name	These fields are used as credentials for the profile selected in the <b>Wireless Profile</b> field. The <b>Password</b> fields is limited to 63 characters. The <b>Username</b> and <b>Domain Name</b> fields combined are limited to 63 characters. Note if any of the above field labels are red, the entry is mandatory; if the field labels are black, the entry is optional.
Mask Password Checkbox	Select this checkbox to mask the password field (so it displays only the '*' character). This is the default. Uncheck this to unmask the field (so it displays the entered text).
Status	This field indicates the reason the dialog is open.

Tapping **OK** sends the credentials though the Wireless Application API. If you did not enter credentials, a dialog box prompts you to fill in all required fields.

The **Log Off** button only displays when you are already logged on. When you tap the **Log Off** button, you are prompted with three options: **Log Off**, **Switch Users**, and **Cancel**. Switching users logs you off and re-initializes the login dialog box when there is no user logged on. Logging off closes the login dialog box. Tapping **Cancel** closes the **Log Off** dialog box and displays the **Login** dialog box.

When logged off, the device only roams to profiles that do not require credentials or to profiles that were created with the credentials entered into the profile.

The **Cancel** button closes the dialog without logging into the network. If the login dialog was launched by the Wireless Application and not by the user, tapping **Cancel** first causes a message box to display a warning that the cancel disables the current profile. If you still choose to cancel the login, the profile is cancelled.

Once you cancel a profile, the profile is suppressed until you actively re-enable it or a new user logs onto the device.



# Appendix C Troubleshooting

---

## Overview

The MK4000 troubleshooting is provided in three sections:

- [Troubleshooting on page C-2](#) offers troubleshooting scenarios for the MK4000.
- [MK4000 Version Information on page C-4](#) describes how to identify the MK4000 version.

## Troubleshooting Notes

When configuring the MK4000, save and reboot the MK4000 to apply the changes.

---

## Troubleshooting

- [MK4000 does not turn on on page C-2](#)
- [MK4000 appears to lock up upon bootup on page C-2](#)
- [MK4000 does not respond to polls from the host computer on page C-2](#)
- [MK4000 does not send data to host computer on page C-2](#)
- [Scanner does not recognize configuration bar codes on page C-2](#)
- [Reg file values are not copied into the Registry at boot time on page C-2](#)
- [The screen does not respond to pen input on page C-2](#)
- [Need to determine a device MAC address on page C-2](#)
- [The wireless MK4000 does not retain its WEP Key encryption after a reboot on page C-3](#)
- [The Mobile Companion icon does not appear in the task tray on page C-3](#)
- [When downloading files to the MK4000 from a .zip file using ActiveSync, a message displays indicating there is not enough free disk space to copy the application on page C-3](#)
- [When downloading a large file over Ethernet, IE issues an insufficient memory message on page C-3](#)
- [When upgrading using an SD card, the MK4000 cannot find files on the card on page C-3](#)
- [Flash file system is corrupt on page C-3](#)

- [Copying large amount of files from PC card to the application folder fails with error "Access is denied" on page C-3](#)

**Table C-1** Troubleshooting

Problem	Possible Causes	Possible Solutions
MK4000 does not turn on	No power to the MK4000.	Connect the Symbol approved power supply to an AC power source and to the MK4000 power connector. See <a href="#">Figure 1-2 on page 1-3</a> .
MK4000 appears to lock up upon bootup	A utility with no user interface was specified as the first user application, or user application failed to run.	Either specify no user application, or a UI-based application as the first user application. If no user application is specified, Explorer.exe is used. Note: this is a substitution of Explorer.exe as the user application, not protected mode.
MK4000 does not respond to polls from the host computer	No communication between the host and MK4000.	Check cables to the MK4000. Ensure the MK4000 address is the address the host is polling.  Check communication parameters.  Open a command window using <b>Start &gt; Programs &gt; Command</b> and type <b>ipconfig</b> to list the status of all radio and Ethernet interfaces.
MK4000 does not send data to host computer	MK4000 is not programmed to work with the host.	Check setup communication parameters.
	MK4000 is not connected to the host.	Check cables to host computer.
Scanner does not recognize configuration bar codes	The scan driver does not support parameter bar code scanning.	Configure the scanner using scanning C API or Active X scanner object.
Reg file values are not copied into the Registry at boot time	More than one .reg file and duplicate registry entries are present.	Review all .reg files in /Application and /Platform and ensure they have no conflicts.
The screen does not respond to pen input	The screen is not properly calibrated, or is off center.	Re-calibrate the screen.
Need to determine a device MAC address	N/A	Open <b>Start &gt; Programs &gt; Command Prompt</b> . Type <b>ipconfig /all</b> to display the MAC address next to 'address'.

**Table C-1** Troubleshooting (Continued)

Problem	Possible Causes	Possible Solutions
The wireless MK4000 does not retain its WEP Key encryption after a reboot	Encryption keys not saved in Spectrum24.reg.	Set encryption keys using Mobile Companion, then select <b>Start &gt; Tools &gt; Save Spectrum24</b> to save them to Spectrum24.reg. Check communication parameter settings. Open a command window using <b>Start &gt; Programs &gt; Command</b> and type <b>ipconfig</b> to list the status of all radio and Ethernet interfaces.
The Mobile Companion icon does not appear in the task tray	The radio software is not present in the \platform folder.	Verify presence of radio software or re-install \Platform partition software.
When downloading files to the MK4000 from a .zip file using ActiveSync, a message displays indicating there is not enough free disk space to copy the application	Files cannot download directly from a .zip file.	Extract/unzip the files to the host computer, then transfer the unzipped files to the MK4000 using ActiveSync.
When downloading a large file over Ethernet, IE issues an insufficient memory message	For some file types, IE requires free RAM equivalent to twice the file's size.	This is an IE limitation.
When upgrading using an SD card, the MK4000 cannot find files on the card	The SD card is not supported.	The MK4000 supports up to an 8 GB SD card.
Flash file system is corrupt	Reset or power loss during write to file system.	Format file system partition using <b>Start &gt; Settings &gt; Control Panel &gt; Storage Manager</b> , and re-install partition data.
Copying large amount of files from PC card to the application folder fails with error "Access is denied"	Archive bit of the folder properties set.	Clear the archive bit of folder properties.
When using SaveConfig to save settings and cycling power before the Save Complete message appears, the device does not boot properly. Similarly, when using ActiveX or C API to save configurations, the device does not boot properly.	Corrupt mkconfig.reg file.	Use ActiveSync to delete the existing mkconfig.reg file or use Monitor to repartition the Application partition.

If problems still occur, see [MK4000 Version Information on page C-4](#) for system information before calling for service help.

---

## MK4000 Version Information

If an MK4000 is configured to launch an application on power-up, bypass this upon booting to access the Windows® CE Desktop. See [Accessing the Windows® CE Desktop on page 4-2](#).

1. From the Windows® task bar, select **Start > Settings > Control Panel**.
2. Select **MK4000** identification from the Control Panel window to view the following information:
  - Device name
  - Description
  - OS version
  - Monitor version
  - Display type
  - Memory sizes.

# Appendix D MK4000 Demo

---

## Overview

This appendix provides information on the MK4000 demo which illustrates device functions. For demo material, including the cell phone coupon bar code, visit <https://devcentral.symbol.com/shwmessage.aspx?ForumID=256&MessageID=15967>

---

## Price Check #1

The Price Check #1 demo opening screen shows the price in large text with a small text description. From the main screen, this demo has a button to show a non-functioning paging feature (it plays sound), a non-functioning printing screen, and another button to check inventory. The inventory screen shows the location of items in stock and can show inventory at other store locations. The final inventory screen allows reserving merchandise by scanning a loyalty card.

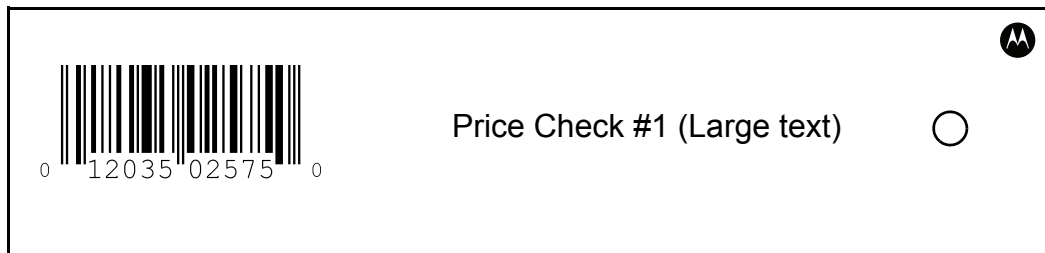

**Figure D-1** *Price Check #1 (Large text)*

---

## Price Check #2

The Price Check #2 demo opening screen shows smaller text than Price Check #1 but includes regular price, sale price, and "you save" information. From the main screen, this demo has a button to show a non-functioning paging feature (it plays sound), a non-functioning printing screen, and another button to check inventory. The inventory screen shows the location of items in stock and can show inventory at other store locations. The final inventory screen allows reserving merchandise by scanning the Loyal Coupon Printing Data Matrix bar code (loyalty card).

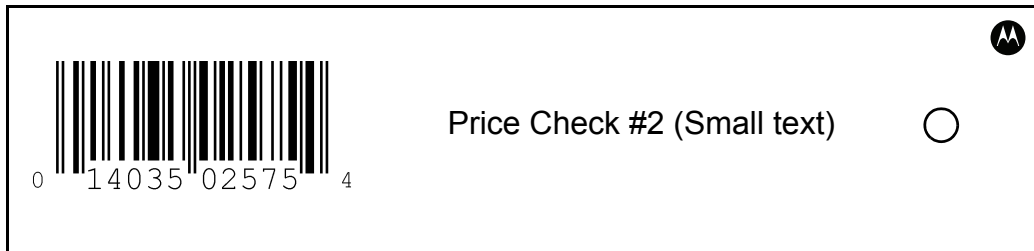

Figure D-2 Price Check #2 (Small text)

---

## Special Order Pick Up

Special Order Pick Up indicates where a customer can pick up an ordered item. After scanning a bar code (loyalty card), the kiosk tells the customer where to pick up an item, and offers an option to have an associate deliver the item. If the customer selects **Yes** for the latter, the kiosk displays a message that an associate was paged and the speaker plays the voice message "associate has been paged."

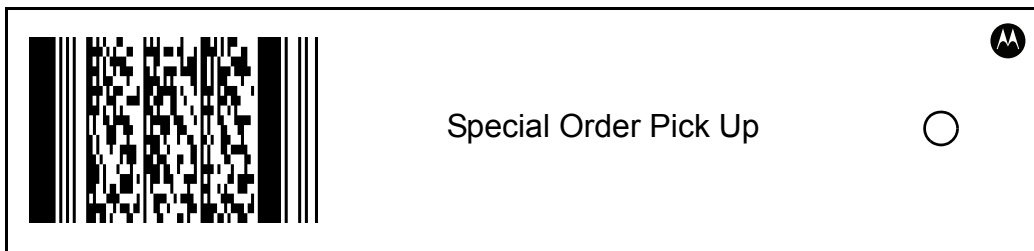

Figure D-3 Special Order Pick Up

---

## Loyalty Coupon Printing

Loyalty Coupon Printing allows a customer to scan a loyalty card to print out coupons at the kiosk.



Figure D-4 Loyalty Coupon Printing

---

## Loyalty Coupon Redemption (Mailer)

Loyalty Coupon Redemption allows scanning a bar code coupon mailed to a customer. After scanning the bar code, the screen indicates the discount the customer is entitled to on one item purchased using the loyalty card. This demo shows that the coupon contains not only the discount information but also information that uniquely identifies the customer.

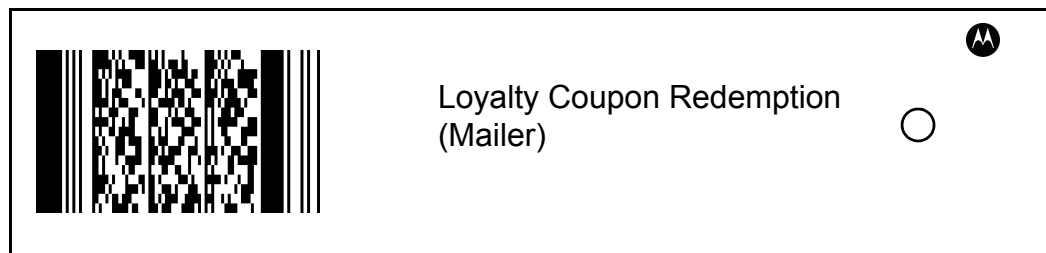

Figure D-5 Loyalty Coupon Redemption (Mailer)

---

## Cell Phone Coupon

Cell Phone Coupon allows scanning a bar code coupon emailed to a customer's phone. After scanning the demo bar code below, the customer is prompted to scan the bar code on the cell phone. This redeems the coupon and shows what the customer has earned on the loyalty account.

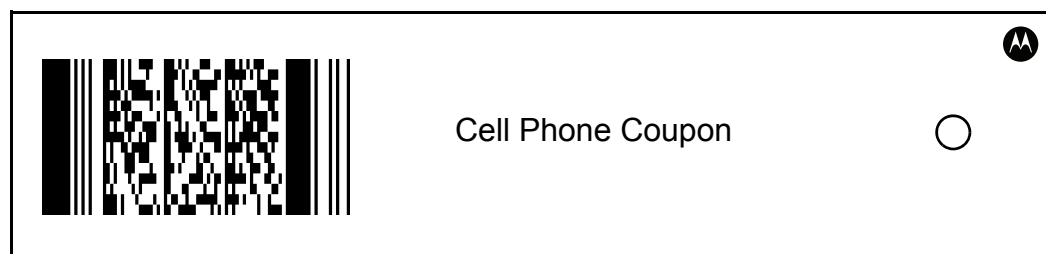

Figure D-6 Cell Phone Coupon

---

## Lottery Win Verification

Lottery Win Verification allows a customer to scan a lottery ticket to see if it is a winning ticket. This demo displays a message on the screen and plays a voice message indicating that the ticket is a winning ticket.

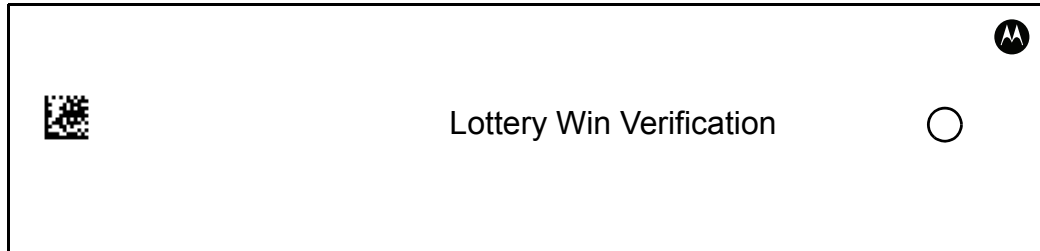

Figure D-7 *Lottery Win Verification*

---

## Employee Application

Employee Application demonstrates an employee management system. It allows an associate to scan a badge to clock in, clock out, check task status, and check the schedule. On the **My Tasks** screen, the user can press **Restock End Caps** to drill down and see more information. A simulated print also occurs from the **My Tasks** screen or **Schedule** screen if the **Print** button is pressed.

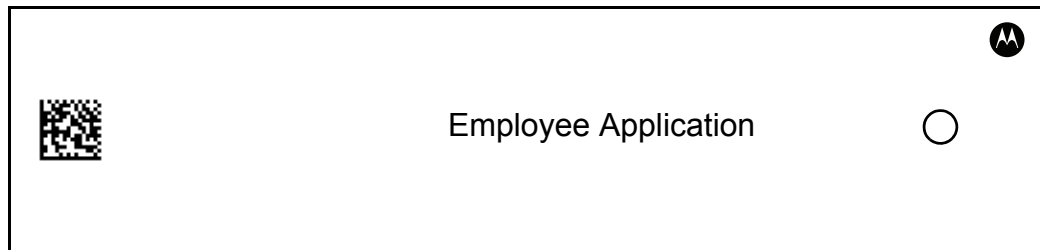

Figure D-8 *Employee Application*



# Index

## Numerics

- 104-Bit WEP ..... B-22
- 40-Bit WEP ..... B-21
- 802.11 ESSID ..... B-6

## A

- AC power supply ..... 2-2
- accessing the Windows® CE desktop ..... 4-2
- ActiveSync ..... 5-5, 5-7
  - connecting ..... 5-5
  - downloading files ..... 5-5
  - installing ..... 5-5
- ad-hoc ..... B-7, B-45
- Advanced Encryption Standard ..... B-22
- advertisement insert ..... 2-9, 2-12
- AES ..... B-22
- aiming
  - pattern ..... 1-8
- AP networks ..... B-45
- authentication
  - EAP-FAST ..... B-11
  - EAP-TLS ..... B-11
  - LEAP ..... B-12
  - none ..... B-11
  - PEAP ..... B-12

## B

- bar code scanner ..... 1-4
- bluetooth
  - ad-hoc mode ..... B-7

## C

- CAB files ..... 3-1

- calibration ..... 5-15, C-2
- CHAP ..... B-13
- chapter descriptions ..... ix
- clock ..... 4-2
- cold boot ..... 5-18
- communications ..... 2-2
  - ethernet, wired ..... 2-3
  - USB ..... 2-2, 2-3
  - wired ethernet ..... 2-2
- companion programs
  - internet explorer ..... 4-5
  - media player ..... 4-5
  - wordpad ..... 4-5
- configuration file
  - downloading ..... 3-4
- configurations ..... ix
- connecting ..... 2-2
  - host ..... 2-3
  - peripherals ..... 2-3
  - power supply ..... 2-2
  - to host computer ..... 5-5
  - USB ..... 2-3
  - wired ethernet ..... 2-3
- country code ..... B-8
- cpf file ..... 3-1
  - creating via SCM ..... 3-1
- creating splash screen ..... 5-17

## D

- date ..... 4-2
- DCP ..... 5-1, 5-7
- default gateway ..... B-25
- demo ..... D-1
- deployment
  - file ..... 3-4
- developer kits

- EMDK for C . . . . . 5-1
- EMDK for NET . . . . . 5-2
- EMDK for the web . . . . . 5-2
- PocketBrowser . . . . . 5-3
- Device Configuration Package . . . . 5-1, 5-8, 5-11, 5-17,  
. . . . . 5-18, 5-19
- DNS . . . . . B-25, B-26
- download
  - configuration file . . . . . 3-4
  - files . . . . . 5-5
  - to host computer . . . . . 5-6

**E**

- EAP-FAST . . . . . B-11
- EAP-GTC . . . . . B-13
- EAP-TLS . . . . . B-11
- EMDK for C . . . . . 5-1
- EMDK for Java . . . . . 5-1
- EMDK for Net . . . . . 5-1
- EMDKs
  - for C . . . . . 5-1
  - for NET . . . . . 5-2
  - for the web . . . . . 5-2
  - PocketBrowser . . . . . 5-3
- encryption
  - open system . . . . . B-21, B-25
  - TKIP (WPA) . . . . . B-22
- Enterprise Mobility Developer Kit for C . . . . . 5-1
- Enterprise Mobility Developer Kit for Java . . . . . 5-1
- Enterprise Mobility Developer Kit for Net . . . . . 5-1
- Enterprise Mobility Developer Kits (EMDKs) . . . . . 1-5
- error messages . . . . . 5-15
- ESSID . . . . . B-6
- ethernet setup . . . . . 2-3
  - Bias-T port connection . . . . . 1-3
  - wired . . . . . 2-3
- external ports . . . . . 1-3

**F**

- features . . . . . 1-4
- file deployment . . . . . 3-4
- file explorer . . . . . 5-9
- flash file system . . . . . 5-18
  - downloading partitions . . . . . 5-19
  - non-FFS partitions . . . . . 5-19
  - splash screen . . . . . 5-19
  - partitions . . . . . 5-18
    - copyfile . . . . . 5-19
    - regmerge . . . . . 5-18
- flash memory . . . . . 4-2
- flash storage . . . . . 5-18
- font loading . . . . . 4-3

**G**

- gateway . . . . . B-26

**H**

- headset jack . . . . . 1-4
- host communications
  - ethernet, wired . . . . . 2-3
  - USB . . . . . 2-3

**I**

- IE . . . . . 1-4
- imaging . . . . . 1-8
- information, service . . . . . xi
- infrastructure . . . . . B-7
- input panel . . . . . 4-5
- installing
  - ActiveSync . . . . . 5-5
  - advertisement insert . . . . . 2-9, 2-12
  - connecting . . . . . 2-2
  - development tools . . . . . 5-4
  - mounting . . . . . 2-5
  - pole mounting . . . . . 2-7
  - VESA mount . . . . . 2-5
  - wall mounting . . . . . 2-6
- internet explorer . . . . . 4-5
- IP address . . . . . B-26
- IP config
  - DNS . . . . . B-26
  - gateway . . . . . B-26
  - IP address . . . . . B-26
  - subnet mask . . . . . B-26
  - WINS . . . . . B-26

**K**

- keyboard
  - virtual . . . . . 4-5

**L**

- LEAP . . . . . B-12
- loading fonts . . . . . 4-3

**M**

- MD5 . . . . . B-13
- media player . . . . . 1-4, 4-5
- memory . . . . . 1-4
  - flash . . . . . 4-2
  - RAM . . . . . 4-2
  - storage . . . . . 4-2

- memory management . . . . . 4-2
- micro SD card . . . . . 1-4
  - inserting . . . . . 2-2
- microsoft applications
  - internet explorer . . . . . 4-5
  - media player . . . . . 4-5
  - wordpad . . . . . 4-5
- Mobility Services Platform Console . . . . . 5-17
- mode
  - 802.11 ESSID . . . . . B-6
  - ad-hoc . . . . . B-7
  - country . . . . . B-8
  - infrastructure . . . . . B-7
  - operating . . . . . B-7
  - profile name . . . . . B-6
- mounting . . . . . 1-5, 2-5
  - pole . . . . . 2-7
  - VESA . . . . . 2-5
  - wall . . . . . 2-6
- MS CHAP . . . . . B-13
- MS CHAP v2 . . . . . B-14
- MSP . . . . . 5-17

## N

- nonvolatile memory . . . . . 4-2
- notational conventions . . . . . x
- NTP, see SNTP

## O

- open system . . . . . B-21, B-25
- operating mode . . . . . B-7
- operating system upgrade . . . . . 5-7
- OS upgrade . . . . . 5-7

## P

- PAP . . . . . B-14
- partitions
  - downloading . . . . . 5-19
  - FFS . . . . . 5-18
  - non-FFS . . . . . 5-19
  - splash screen . . . . . 5-19
- parts . . . . . 1-1
- PC card . . . . . 4-2, 4-4, C-3
  - access cover . . . . . 1-3
- PC download . . . . . 5-8
- PCMCIA . . . . . 4-2, 4-4, C-3
  - access cover . . . . . 1-3
- PEAP . . . . . B-12
- peripheral connection
  - USB . . . . . 2-3
- PocketBrowser . . . . . 5-3

- POE . . . . . 1-3
  - setup . . . . . 2-3
- ports
  - ethernet . . . . . 2-3
  - Ethernet/Bias-T . . . . . 1-3
  - headset jack . . . . . 1-4
  - power . . . . . 1-3
  - RJ45 . . . . . 1-3
  - USB . . . . . 1-3, 2-3
- power . . . . . 1-3
  - AC power supply . . . . . 1-4, 2-2
  - options . . . . . 1-4, 2-2
  - POE . . . . . 2-3
  - supply . . . . . 1-3
- power-over-ethernet . . . . . 1-3
  - setup . . . . . 2-3
- printer
  - connecting . . . . . 2-3
  - debugging . . . . . 4-5
- profile
  - create new . . . . . B-32
  - delete . . . . . B-32
  - edit . . . . . B-31
  - name . . . . . B-6
- program memory . . . . . 4-2
- programs
  - flash file system . . . . . 5-18

## R

- RAM memory . . . . . 4-2
- rapid deployment client . . . . . 5-17
- RD . . . . . 5-17
- rebooting . . . . . 3-4
- recalibrate . . . . . 5-15
- related publications . . . . . xi

## S

- scan beam . . . . . 1-6
- scanner . . . . . 1-4
  - connecting . . . . . 2-3
  - window . . . . . 1-2
- scanning . . . . . 1-6
  - bar code scanning . . . . . 1-6
- SCM
  - file deployment . . . . . 3-4
  - file types . . . . . 3-1
  - menu . . . . . 3-2
  - parameter indicators . . . . . 3-3
  - user interface . . . . . 3-2
  - XML provisioning . . . . . 3-1
- screen calibration . . . . . 5-15, C-2
- screen protector . . . . . 2-2

- scripts
  - creating ..... 5-11
  - saving ..... 5-12
- SD card, micro ..... 1-4, C-3
  - inserting ..... 2-2
- service information ..... xi
- setup
  - advertisement insert ..... 2-9, 2-12
  - inserting micro SD card ..... 2-2
  - mounting ..... 2-5
  - peripherals ..... 2-3
  - pole mounting ..... 2-7
  - power supply ..... 2-2
  - printer ..... 2-3
  - scanner ..... 2-3
  - USB to host ..... 2-3
  - VESA mount ..... 2-5
  - wall mounting ..... 2-6
  - wired ethernet ..... 2-3
  - wired ethernet AC outlet ..... 2-3
  - wired ethernet, POE ..... 2-3
- signal strength ..... B-3, B-37
- Simple Network Time Protocol, see SNTP
- SNTP ..... 4-2
- software ..... 1-4
- software developer kits
  - EMDK for C ..... 5-1
  - EMDK for NET ..... 5-2
  - EMDK for the web ..... 5-2
  - PocketBrowser ..... 5-3
- speakers ..... 1-1
- specifications ..... A-1
- specular reflection ..... 1-7
- splash screen ..... 5-19
  - creating ..... 5-17
- static ..... B-25
- storage memory ..... 4-2
- subnet mask ..... B-26
- Symbol configuration manager
  - file deployment ..... 3-4
  - file types ..... 3-1
  - menu ..... 3-2
  - parameter indicators ..... 3-3
  - user interface ..... 3-2
  - XML provisioning ..... 3-1

## T

- TCM
  - building hex image ..... 5-8, 5-12, 5-13
  - creating script ..... 5-11
  - defining properties ..... 5-10
  - error messages ..... 5-15
  - hex image download ..... 5-13

- saving script ..... 5-12
  - starting ..... 5-9
- technical specifications ..... A-1
- time ..... 4-2
- TKIP (WPA) ..... B-22
- TLS ..... B-14
- touch screen ..... 1-4
- troubleshooting ..... C-2

## U

- unpacking ..... 2-1
- updating data
  - time ..... 4-2
- upgrade
  - OS ..... 5-7
- USB
  - cable ..... 5-7
  - communications ..... 2-2
  - host connection ..... 2-3
  - peripheral connection ..... 2-3
  - port ..... 1-3

## V

- virtual keyboard ..... 4-5
- volatile memory ..... 4-2

## W

- WINS ..... B-25, B-26
- wireless local area networks ..... B-2
- wordpad ..... 4-5

## X

- XML provisioning
  - SCM ..... 3-1

# *Tell Us What You Think...*

We'd like to know what you think about this Manual. Please take a moment to fill out this questionnaire and fax this form to: (631) 627-7184, or mail to:

Motorola, Inc.  
One Motorola Plaza M/S B-10  
Holtsville, NY 11742-1300  
Attention: Technical Publications Manager  
Advanced Data Capture Division

**IMPORTANT:** If you need product support, please call the appropriate customer support number provided. Unfortunately, we cannot provide customer support at the fax number above.

Manual Title: \_\_\_\_\_  
(please include revision level)

How familiar were you with this product before using this manual?

Very familiar     Slightly familiar     Not at all familiar

Did this manual meet your needs? If not, please explain.

---

---

---

---

What topics need to be added to the index, if applicable?

---

---

---

---

What topics do you feel need to be better discussed? Please be specific.

---

---

---

---

What can we do to further improve our manuals?

---

---

---

---

Thank you for your input—We value your comments.







**MOTOROLA**

Motorola, Inc.  
One Motorola Plaza  
Holtsville, New York 11742, USA  
1-800-927-9626  
<http://www.motorola.com/enterprisemobility>

MOTOROLA and the Stylized M Logo and Symbol and the Symbol logo are registered in the U.S. Patent and Trademark Office.  
All other product or service names are the property of their respective owners.  
© Motorola, Inc. 2010



72E-121864-02 Revision A - May 2010